

FMP060-25-IPM

FlexPro® Series

Product Status: Active

SPECIFICATIONS

Current Peak	50 A
Current Continuous	25 A
DC Supply Voltage	10 – 55 VDC
Network Communication	Ethernet IP

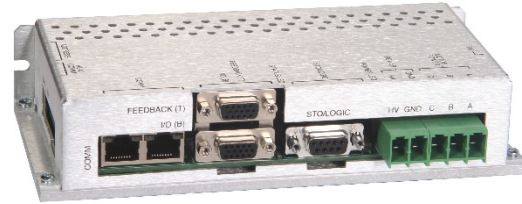

The **FMP060-25-IPM** is a servo drive and integration board assembly for a FE060-25-IPM FlexPro® series servo drive with IMPACT™ architecture. Connections to the controller, motor, power, and feedback are simplified through the standard connectors. The assembly is housed within a case, allowing vertical and horizontal panel mounting orientations.

The **FMP060-25-IPM** offers full tuning control of all servo loops and is designed to drive brushed and brushless servo motors, stepper motors, and AC induction motors. The drive assembly accepts a variety of external command signals, or can use the built-in Motion Engine, an internal motion controller used with Sequencing and Indexing commands. Programmable digital and analog I/O are included to enhance interfacing with external controllers and devices.

The **FMP060-25-IPM** utilizes Ethernet IP network communication and is configured via USB. All drive and motor parameters are stored in non-volatile memory.

IMPACT™ (Integrated **M**otion **P**latform **A**nd **C**ontrol **T**echnology) combines exceptional processing capability and high-current components to create powerful, compact, feature-loaded servo solutions. IMPACT™ is used in all FlexPro® drives and is available in custom products as well.

FEATURES

- Four Quadrant Regenerative Operation
- Programmable Gain Settings
- PIDF Velocity Loop
- On-the-Fly Mode Switching
- On-the-Fly Gain Set Switching
- Dedicated Safe Torque Off (STO) Inputs
- Bridge Status, Fault and Network Status LEDs
- Integrated Cooling Fan
- Standard Connections for Easy Setup

Feedback Supported	<ul style="list-style-type: none"> • Incremental Encoder • Hall Sensors • Tachometer (±10V) 	Motors Supported	<ul style="list-style-type: none"> • Three Phase • Single Phase • Stepper 	Modes of Operation	<ul style="list-style-type: none"> • Profile Modes • Cyclic Synchronous Modes • Current • Velocity • Position
Command Sources	<ul style="list-style-type: none"> • Over the Network • ±10V Analog • Sequencing • Indexing • Jogging 	Inputs / Outputs	<ul style="list-style-type: none"> • 4 Programmable Digital Inputs • 3 Programmable Digital Outputs • 1 Programmable Analog Input 	Agency Approvals	<ul style="list-style-type: none"> • RoHS • UL (Pending) • CE (Pending) • TUV Rheinland (STO) (Pending)

BLOCK DIAGRAM

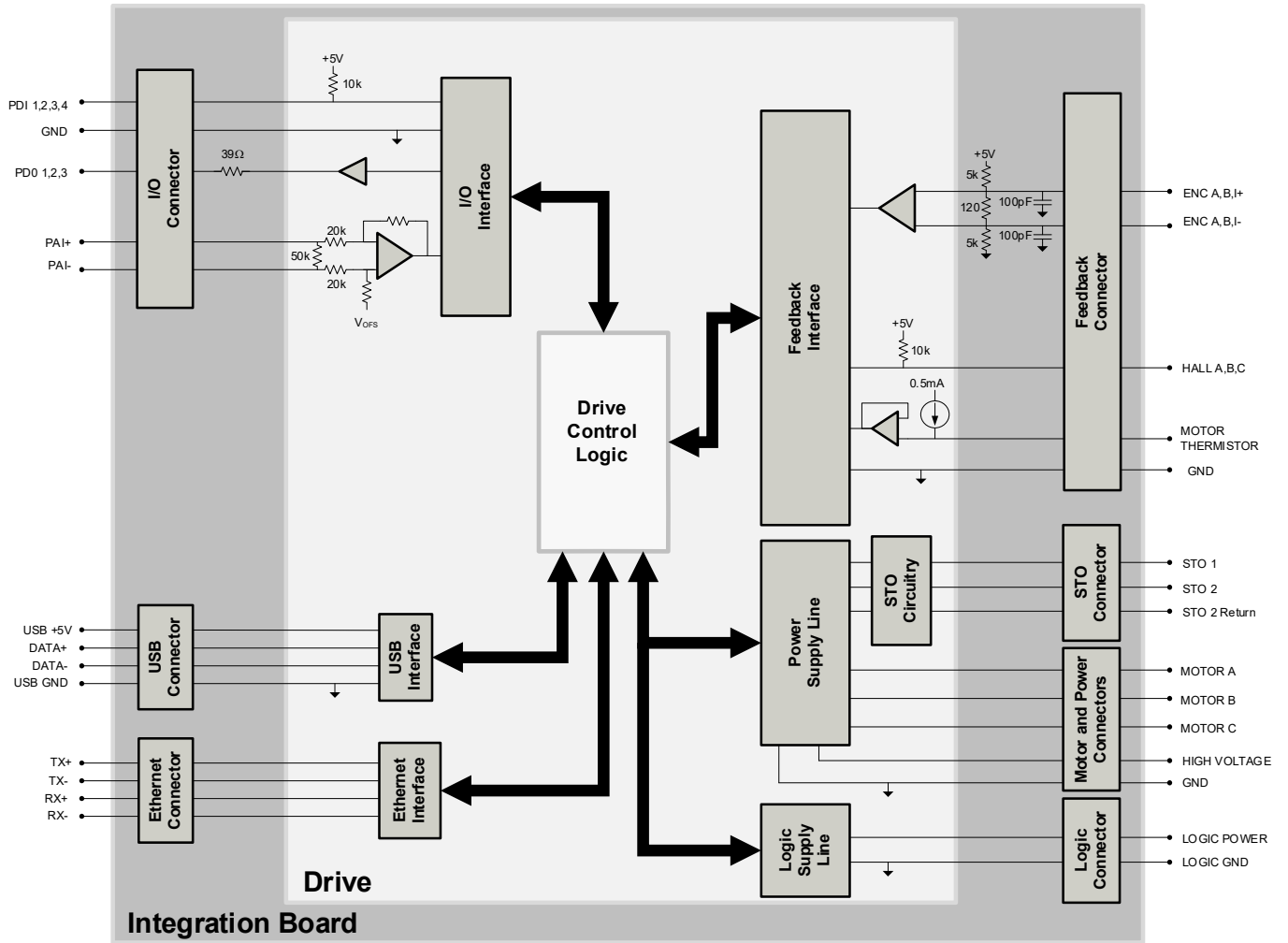

INFORMATION ON APPROVALS AND COMPLIANCES



The RoHS Directive restricts the use of certain substances including lead, mercury, cadmium, hexavalent chromium and halogenated flame retardants PBB and PBDE in electronic equipment.

SPECIFICATIONS

Description	Electrical Specifications		Value
	Units		
Nominal DC Supply Voltage Range	VDC	12 – 48	
DC Supply Input Range	VDC	10 – 55	
DC Supply Undervoltage	VDC	8	
DC Supply Overvoltage	VDC	58	
Logic Supply Input Range (optional)	VDC	10 – 55	
Safe Torque Off Voltage	VDC	24	
Bus Capacitance	µF	221	
Maximum Peak Current Output ¹	A (Arms)	50 (35.3)	
Maximum Continuous Current Output ²	A (Arms)	25 (25)	
Efficiency at Rated Power	%	99	
Maximum Continuous Output Power	W	1361	
Maximum Power Dissipation at Rated Power	W	14	
Minimum Load Inductance (line-to-line) ³	µH	150 (@ 48VDC supply); 75 (@24VDC supply); 40 (@12VDC supply)	
Switching Frequency	kHz	20	
Maximum Output PWM Duty Cycle	%	83	

Description	Control Specifications		Value
	Units		
Communication Interfaces	-	Ethernet IP (USB for configuration)	
Command Sources	-	±10 V Analog, Over the Network, Sequencing, Indexing, Jogging	
Feedback Supported	-	Incremental Encoder, Hall Sensors, Tachometer (±10V)	
Commutation Methods	-	Sinusoidal, Trapezoidal	
Modes of Operation	-	Profile Modes, Cyclic Synchronous Modes, Current, Velocity, Position	
Motors Supported ⁴	-	Three Phase (Brushless Servo), Single Phase (Brushed Servo, Voice Coil, Inductive Load), Stepper (2- or 3-Phase Closed Loop)	
Hardware Protection	-	40+ Configurable Functions, Over Current, Over Temperature (Drive & Motor), Over Voltage, Short Circuit (Phase-Phase & Phase-Ground), Under Voltage	
Programmable Digital Inputs/Outputs	-	4/3	
Programmable Analog Inputs/Outputs	-	1/0	
Primary I/O Logic Level	VDC	24	
Current Loop Sample Time	µs	50	
Velocity Loop Sample Time	µs	100	
Position Loop Sample Time	µs	100	
Maximum Encoder Frequency	MHz	20 (5 pre-quadrature)	

Description	Mechanical Specifications		Value
	Units		
Size (H x W x D)	mm (in)	190.50 x 88.90 x 41.28 (7.50 x 3.50 x 1.63)	
Weight	g (oz)	484.8 (17.1)	
Relative Humidity	-	0-95%	
Ambient Operating Temperature	°C (°F)	0 – 40 (32 – 104)	
Storage Temperature	°C (°F)	-20 – 85 (-4 – 185)	
Shock	-	15g, 11ms, Half-sine	
Vibration	-	30 grms for 5 minutes in 3 axes	
IP Rating	-	IP20	
P1 POWER CONNECTOR	-	2-port, 7.62mm spaced, enclosed, friction lock header	
P2 MOTOR POWER CONNECTOR	-	3-port, 7.62mm spaced, enclosed, friction lock header	
P3 IO CONNECTOR	-	15-pin high-density female D-Sub	
P4 FEEDBACK CONNECTOR	-	15-pin high-density female D-Sub	
P5 ETHERNET COMMUNICATION CONNECTORS	-	Shielded, Dual RJ-45 socket with LEDs	
P6 STO / LOGIC CONNECTOR	-	9-pin female D-sub	
P7 USB COMMUNICATION CONNECTOR	-	5-pin, Mini USB B Type port	

Notes

1. Capable of supplying drive rated peak current for 2 seconds with 10 second foldback to continuous value. Longer times are possible with lower current limits.
2. Continuous A_{rms} value attainable when RMS Charge-Based Limiting is used.
3. Lower inductance is acceptable for bus voltages well below maximum. Use external inductance to meet requirements.
4. Maximum motor speed for stepper motors is 600 RPM. Consult the hardware installation manual for 2-phase stepper wiring configuration.

PIN FUNCTIONS

P1 - Power Connector

Pin	Name	Description / Notes	I/O
1	POWER GROUND	Power Ground. (Common with Signal Ground)	GND
2	HIGH VOLTAGE	DC Supply Input (10-55 VDC).	I
Connector Information		2-port, 7.62mm spaced, enclosed, friction lock header	
Mating Connector Details		Amphenol: P/N ET020150000G	
Mating Connector Included		Yes	

P2 - Motor Power Connector

Pin	Name	Description / Notes	I/O
1	MOTOR A	Motor Phase A.	O
2	MOTOR B	Motor Phase B.	O
3	MOTOR C	Motor Phase C.	O
Connector Information		3-port, 7.62mm spaced, enclosed, friction lock header	
Mating Connector Details		Amphenol: P/N ET030150000G	
Mating Connector Included		Yes	

P7 - IO Connector

Pin	Name	Description / Notes	I/O
1	PDI-1	General Purpose Programmable Digital Input	I
2	PDI-2	General Purpose Programmable Digital Input	I
3	PDI-3	General Purpose Programmable Digital Input	I
4	PDI-4	General Purpose Programmable Digital Input	I
5	PDO-1	General Purpose Programmable Digital Output (24V Open Drain/1A)	O
6	PDO-2	General Purpose Programmable Digital Output (24V Open Drain/1A)	O
7	PDO-3	General Purpose Programmable Digital Output (24V Open Drain/1A)	O
8	RESERVED	Reserved.	-
9	GND	Signal Ground. (Common with Power Ground)	GND
10	GND	Ground.	GND
11	PAI-1+	General Purpose Differential Programmable Analog Input or Reference Signal Input. ±10VDC Range (12-bit Resolution)	I
12	PAI-1-		I
13	RESERVED	Reserved.	-
14	RESERVED	Reserved.	-
15	RESERVED	Reserved.	-
Connector Information		15-pin high-density female D-Sub	
Mating Connector Details		TYCO: Plug P/N 748364-1; Housing P/N 5748677-2; Terminals P/N 1658670-2 (loose) or 1658670-1 (strip)	
Mating Connector Included		No	

P4 – Feedback Connector			
Pin	Name	Description / Notes	I/O
1	HALL A		I
2	HALL B	Single-ended Commutation Sensor Inputs.	I
3	HALL C		I
4	ENC 1 A+		Differential Incremental Encoder A.
5	ENC 1 A-	I	
6	ENC 1 B+	Differential Incremental Encoder B.	I
7	ENC 1 B-		I
8	ENC 1 I+	Differential Incremental Encoder Index.	I
9	ENC 1 I-		I
10	RESERVED	Reserved.	-
11	RESERVED	Reserved.	-
12	GND	Ground.	GND
13	+5V OUT	+5V Supply Output. Short-circuit protected. (500ma total load capacity)	O
14	THERMISTOR	Motor Thermal Protection.	I
15	RESERVED	Reserved.	-

Connector Information	15-pin high-density female D-Sub	
Mating Connector Details	TYCO: Plug P/N 748364-1; Housing P/N 5748677-2; Terminals P/N 1658670-2 (loose) or 1658670-1 (strip)	
Mating Connector Included	No	

P4 – Ethernet Communication Connectors			
Pin	Name	Description / Notes	I/O
1	RX+	Receiver + (100Base-TX)	I
2	RX-	Receiver - (100Base-TX)	I
3	TX+	Transmitter + (100Base-TX)	O
4	RESERVED	Reserved.	-
5	RESERVED	Reserved.	-
6	TX-	Transmitter - (100Base-TX)	O
7	RESERVED	Reserved.	-
8	RESERVED	Reserved.	-

Connector Information	Shielded, dual RJ-45 socket with LEDs	
Mating Connector Details	CAT 5 Cable	
Mating Connector Included	No	

P6 – STO / Logic Connector			
Pin	Name	Description / Notes	I/O
1	STO RETURN	Safe Torque Off Return	STORET
2	STO-1 INPUT	Safe Torque Off – Input 1	I
3	STO RETURN	Safe Torque Off Return	STORET
4	STO-2 INPUT	Safe Torque Off – Input 2	I
5	RESERVED	Reserved.	-
6	LOGIC POWER	Logic Supply Input.	I
7	RESERVED	Reserved.	-
8	LOGIC GND	Logic Supply Ground. (Common with Signal Ground)	GND

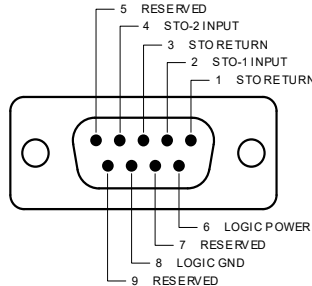
Connector Information	9-pin, female D-sub	
Mating Connector Details	TYCO: P/N 205204-4 (Plug); 5748677-1 (Housing); 1658540-5 (Terminals – Loose); 1658540-4 (Terminals – Strip)	
Mating Connector Included	No	

P7 – USB Communication Connector			
Pin	Name	Description / Notes	I/O
1	VBUS	Supply Voltage	O
2	DATA-	Data -	I/O
3	DATA+	Data +	I/O
4	RESERVED	Reserved.	-
5	GND	Ground	GND

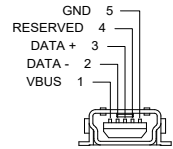
Connector Information	5-pin, Mini USB B Type port	
Mating Connector Details	TYCO: 1496476-3 (2-meter STD-A to MINI-B ASSY)	
Mating Connector Included	No	

BOARD CONFIGURATION

Status LED Functions

LED	Description
STATUS	Indicates drive power bridge status. GREEN when DC bus power is applied and the drive is enabled. RED when the drive is in a fault state.
POWER	Indicates that power is available to the drive. GREEN when power is applied.

Communication Status LED Functions (on RJ-45 Communication Connectors)

LED	Description	
MODULE STATUS	Off	No power
	Green	Device Operational
	Flashing Green	Standby
	Flashing Red	Minor Fault
	Red	Major Fault
	Flashing Green/Red	Self-test
NETWORK STATUS	Off	Not powered, no IP address
	Flashing Green	No connections
	Green	Connected
	Flashing Red	Connection Timeout
	Red	Duplicate IP address
	Flashing Green/Red	Self-test

IP Address Selector Switches

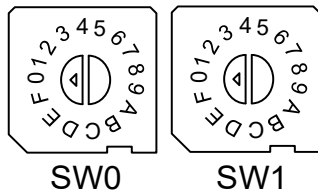
Switch Diagram	Description																								
 <p>SW0 SW1</p>	<p>The IP Address of the drive is set to 192.168.1.xxx. Hexadecimal switch settings correspond to the last octet of the IP address of the drive within the Ethernet network. The IP address is also configurable through software.</p> <table border="1"> <thead> <tr> <th>SW1</th> <th>SW0</th> <th>Last Octet</th> </tr> </thead> <tbody> <tr> <td>0</td> <td>0</td> <td>Address stored in NVM</td> </tr> <tr> <td>0</td> <td>1</td> <td>001</td> </tr> <tr> <td>0</td> <td>2</td> <td>002</td> </tr> <tr> <td>...</td> <td>...</td> <td>...</td> </tr> <tr> <td>F</td> <td>D</td> <td>253</td> </tr> <tr> <td>F</td> <td>E</td> <td>254</td> </tr> <tr> <td>F</td> <td>F</td> <td>255</td> </tr> </tbody> </table>	SW1	SW0	Last Octet	0	0	Address stored in NVM	0	1	001	0	2	002	F	D	253	F	E	254	F	F	255
SW1	SW0	Last Octet																							
0	0	Address stored in NVM																							
0	1	001																							
0	2	002																							
...																							
F	D	253																							
F	E	254																							
F	F	255																							

Safe Torque Off (STO) Inputs

The Safe Torque Off (STO) inputs are dedicated +24VDC sinking single-ended inputs. For applications not using STO functionality, disabling of the STO feature is required for proper drive operation. STO may be disabled by following the STO Disable wiring instructions as given in the hardware installation manual. Consult the hardware installation manual for more information.

MOUNTING DIMENSIONS

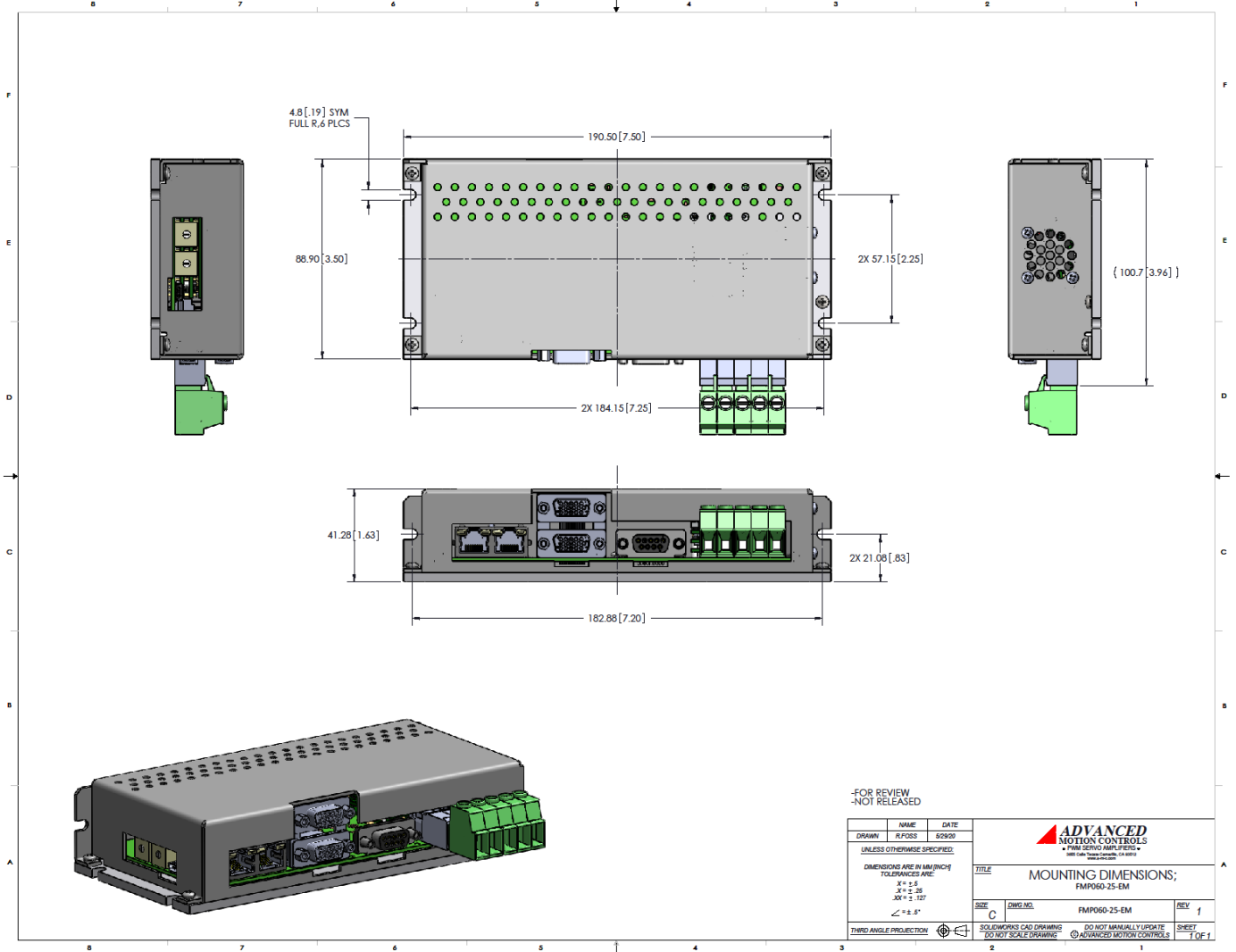

CUSTOMIZATION INFORMATION

ADVANCED Motion Controls also has the capability to promptly develop and deliver specified products for OEMs with volume requests. Our Applications and Engineering Departments will work closely with your design team through all stages of development in order to provide the best servo drive solution for your system. Equipped with on-site manufacturing for quick-turn custom capabilities, ADVANCED Motion Controls utilizes our years of engineering and manufacturing expertise to decrease your costs and time-to-market while increasing system quality and reliability.

Examples of Customized Products

- ▲ Optimized Footprint
- ▲ Private Label Software
- ▲ OEM Specified Connectors
- ▲ No Outer Case
- ▲ Increased Current Resolution
- ▲ Increased Temperature Range
- ▲ Custom Control Interface
- ▲ Integrated System I/O
- ▲ Tailored Project File
- ▲ Silkscreen Branding
- ▲ Optimized Base Plate
- ▲ Increased Current Limits
- ▲ Increased Voltage Range
- ▲ Conformal Coating
- ▲ Multi-Axis Configurations
- ▲ Reduced Profile Size and Weight

Feel free to contact us for further information and details!

Available Accessories

ADVANCED Motion Controls offers a variety of accessories designed to facilitate drive integration into a servo system. Visit www.a-m-c.com to see which accessories will assist with your application design and implementation.

All specifications in this document are subject to change without written notice. Actual product may differ from pictures provided in this document.