

**Features**

- ▲ High power density, compact form factor
- ▲ Fully digital state-of-the-art design
- ▲ Space Vector Modulation technology
- ▲ Programmable gain settings
- ▲ Programmable profiling in all modes
- ▲ Fully configurable current, voltage, velocity and position limits
- ▲ 20kHz digital current loop and vector control
- ▲ PIDF velocity loop with 100µsec sample time (10kHz update rate)
- ▲ PID + FF position loop with 100µsec sample time (10kHz update rate)
- ▲ Four quadrant regenerative operation

**Modes of Operation:**

- Torque (current)
- Velocity
- Position

**Command Source:**

- ±10V programmable analog input (12-bit)
- Step and Direction for stepper replacement
- Encoder Following (Electronic Gearing)
- CANopen Network

**Feedback Supported**

- Incremental Encoder + Halls
- Incremental Encoder only
- Analog Input
- Halls only (Trapezoidal Commutation)

**Inputs/Outputs**

- 2 programmable differential digital inputs (Auxiliary Encoder or Step and Direction input)
- 3 programmable digital inputs
- 3 programmable digital outputs

**Communication**

- RS232 interface for setup
- CANopen interface for embedded machine networking

**Protection**

- Over Voltage (programmable)
- Under Voltage (programmable)
- Short Circuit (phase-to-phase or phase-to-ground)
- Over Current
- Drive Over Temperature
- Motor Over Temperature (via analog or digital input, programmable)

**Agency Approvals**

- UL Recognized 508C, File No: E140173
- CE: EN 55011:1998 Group 1, Class A / EN 50082-2:1995

**Power Range**

Peak Current	12 A (8.6 A <sub>RMS</sub> )
Continuous Current	6 A (4.3 A <sub>RMS</sub> )
Supply Voltage	20 – 80 VDC

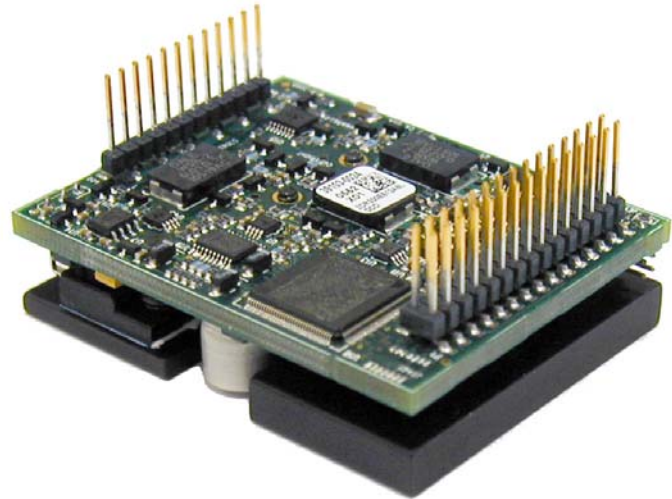
**ZDCR300EE Series**
**Description**

The ZDCR300EE Series digital servo drives are designed to drive brushed and brushless servomotors. These fully digital drives operate in torque, velocity, or position mode and employ Space Vector Modulation (SVM), which results in higher bus voltage utilization and reduced heat dissipation compared to traditional PWM. The command source can be generated internally or can be supplied externally. In addition to motor control, these drives feature dedicated and programmable digital and analog inputs and outputs to enhance interfacing with external controllers and devices.

ZDCR300EE Series drives feature a single RS232 interface used for drive configuration and setup. Drive commissioning is accomplished using DriveWare300 available at [www.a-m-c.com](http://www.a-m-c.com). The CANopen interface can be used for online operation in networked applications.

All drive and motor parameters are stored in non-volatile memory.

## Feature Highlights

### **Mounts Directly onto PCB**

The header pins make it easy to integrate the ZDCR300EE12A8LDC into user PCB designs. Its compact size minimizes the space occupied by the drive.

### **Incorporates 31 Homing Methods**

31 built-in homing methods utilize combinations of Home Switch, Positive Limit Switch, Negative Limit Switch and/or Encoder Index Pulse.

### **Separate Logic Supply Input**

A separate 5V logic supply input keeps the drive logic powered in order to keep track of position or other parameters even when you need to remove the power that drives the motor.

### **Built-in 8-channel Digital Scope**

Drive tuning and performance evaluation is convenient with the built-in 8-channel digital oscilloscope. Over 40 parameters are available.

### **Windows® Based Setup Software**

Configuring and tuning the drive is easy through the use of DriveWare300. The block-diagram interface layout is intuitive and easy to use.

### **PVT Mode**

PVT makes it easy to accomplish multi-axis coordinated motion. A host controller can generate a series of PVT commands containing position, velocity and time of the motion profile segment end points. The drive interpolates between these intermediate points to ensure smooth motion. Send PVT commands to multiple axes to achieve coordinated motion.

### **Encoder Feedback with Hall Sensor or Encoder Only Commutation**

Sinusoidal commutation for high-resolution, smooth motion control can be accomplished using the encoder with or without the Hall sensor feedback.

### **Advanced Event Handling**

The drive continuously monitors over 50 events related to the drive and system status. Each event has several configurable attributes, providing the user with complete control over the drive response to these events.

**BLOCK DIAGRAM**

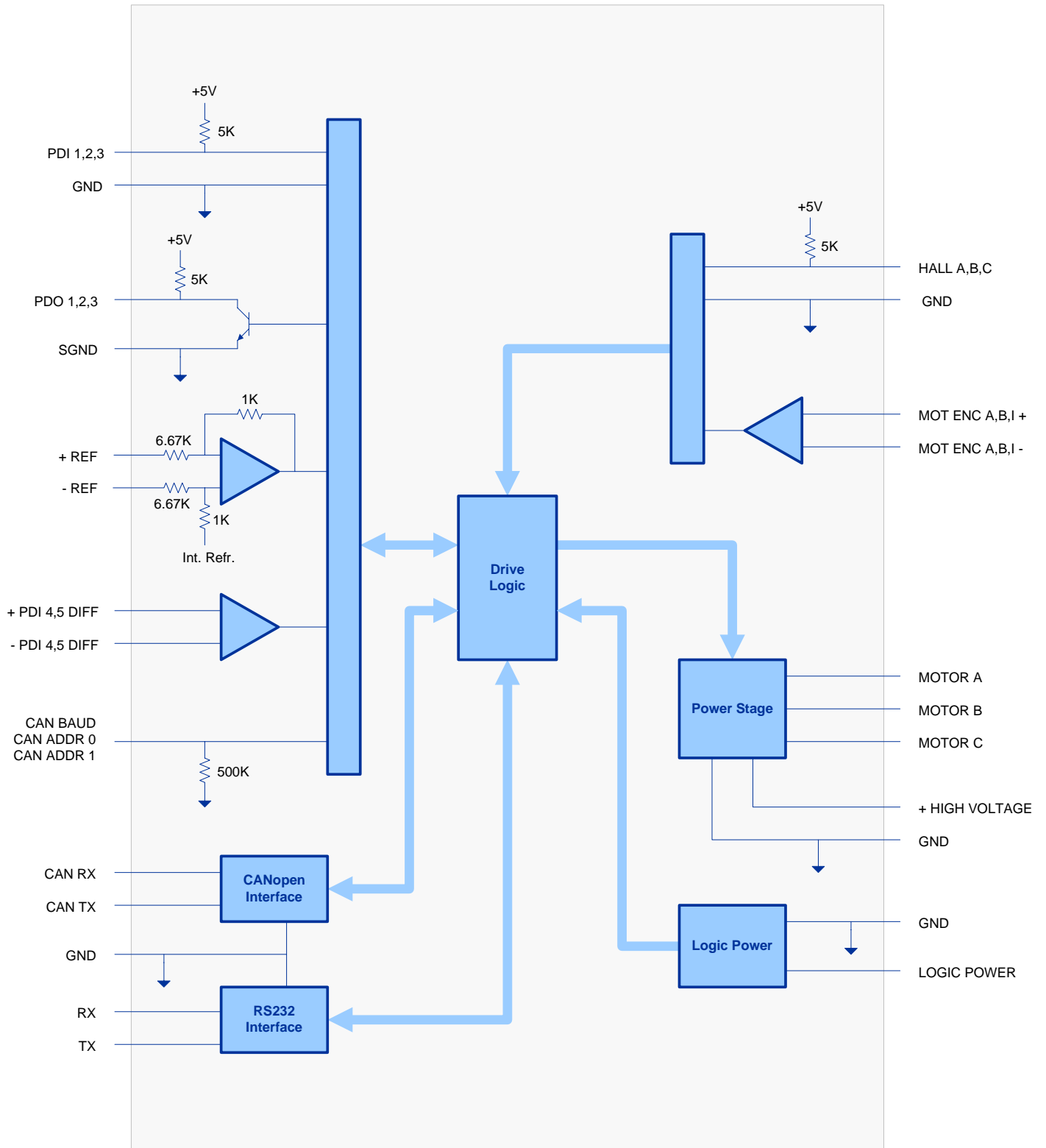

**SPECIFICATION SUMMARY**

Power Stage Specifications	
DC Supply Voltage	20 - 80 V
Peak Output Current	± 12 A (8.6 Arms)
Maximum Continuous Output Current	± 6 A (4.3 Arms)
Minimum Load Inductance*	250 µH
Switching Frequency	20 kHz
Heatsink (Base) Temperature Range	0 ° to + 65° C, disables if > 65° C
Power Dissipation at Continuous Current	18 W
Internal Bus Capacitance	33 µF
Logic Supply Voltage	5 VDC (+/- 5%) @ 0.4A + current consumption of feedback and I/O
Under-Voltage Limit	17 V
Over-Voltage Limit	86 V
Control Specifications	
Commutation Method	Sinusoidal or Trapezoidal (programmable)
Max Encoder Line Frequency	4.0 MHz
Current Loop Sample Time	50 µs
Velocity Loop Sample Time	100 µs
Position Loop Sample Time	100 µs
Mechanical Specifications	
Power Connector: P2	Single row header, 0.1 inch (2.54 mm) spacing
Signal Connector: P1	Dual row header, 0.1 inch (2.54 mm) spacing
Size (L x W x H)	2.5 x 2.0 x 0.73 inches 63.5 x 50.8 x 18.5 mm
Weight	3.4 oz 95.2 g

\* The Minimum Load Inductance provided assumes the highest allowed bus voltage. Lower inductances are acceptable for lower bus voltages.

**PIN FUNCTIONS**

P1 – Signal Connector			
Pin	Name	Description	I/O
1	CAN ADDR 0	CAN bus address selector.	I
2	CAN ADDR 1		
3	-REF IN	Differential analog command input or programmable analog input.	I
4	+REF IN		
5	GND	Signal ground.	-
6	CAN BAUD	CAN bus bit rate selector.	I
7	PDO 1	Programmable digital outputs.	O
8	PDO 2		
9	PDO 3		
10	PDI 1	Programmable digital inputs.	I
11	PDI 2		
12	PDI 3		
13	RX	RS232 receive.	I
14	CAN_RX	CAN receive (requires external transceiver).	I
15	TX	RS232 transmit.	O
16	CAN_TX	CAN transmit (requires external transceiver).	O
17	+PDI 4	Programmable differential digital input, or Step+/Step-, or Aux Enc A+/A-. See MC1XZDCR datasheet for recommended signal conditioning.	I
18	-PDI 4		
19	+PDI 5	Programmable differential digital input, or Direction+/Direction-, or Aux Enc B+/B-. See MC1XZDCR datasheet for recommended signal conditioning.	I
20	-PDI 5		
21	GND	Signal ground.	-
22	HALL A	Hall sensor commutation inputs. Internal 5 kΩ pull-up to +5 V <sub>DC</sub> . For differential inputs see MC1XZDCR datasheet for recommended signal conditioning.	I
23	HALL B		
24	HALL C		
25	ENC I+	Differential encoder index input. See MC1XZDCR datasheet for recommended signal conditioning.	I
26	ENC I-		
27	ENC A+	Differential encoder channel A input. See MC1XZDCR datasheet for recommended signal conditioning.	I
28	ENC A-		
29	ENC B+	Differential encoder channel B input. See MC1XZDCR datasheet for recommended signal conditioning.	I
30	ENC B-		

P2 – Power Connector			
Pin	Name	Description	I/O
1	+5V IN	5V logic supply, +/-5%. Input current is 0.4A + current consumption of feedback and I/O.	I
2	POWER GROUND	Power ground (current rating of 3A per pin).	-
3			
4	HIGH VOLTAGE	DC power input (current rating of 3A per pin).	I
5			
6	N/C	Not connected. Pin has been removed.	-
7	MOTOR C	Motor phase C connection (current rating of 3A per pin).	O
8			
9	MOTOR B	Motor phase B connection (current rating of 3A per pin).	O
10			
11	MOTOR A	Motor phase A connection (current rating of 3A per pin).	O
12			

For more details on pin functionality please refer to the User Manual for this product.

**CONNECTOR INFORMATION**

**P1 – I/O Connector**

Connector Information	Dual Row, 30-pin, 0.1 in (2.54 mm) pitch
Mating Connector Example	Samtec: SSM-115-L-DV

**P2 – Power Connector**

Connector Information	Single-Row, 12-pin, 0.1 in (2.54 mm) pitch
Mating Connector Example	Samtec: BCS-112-L-S-PE

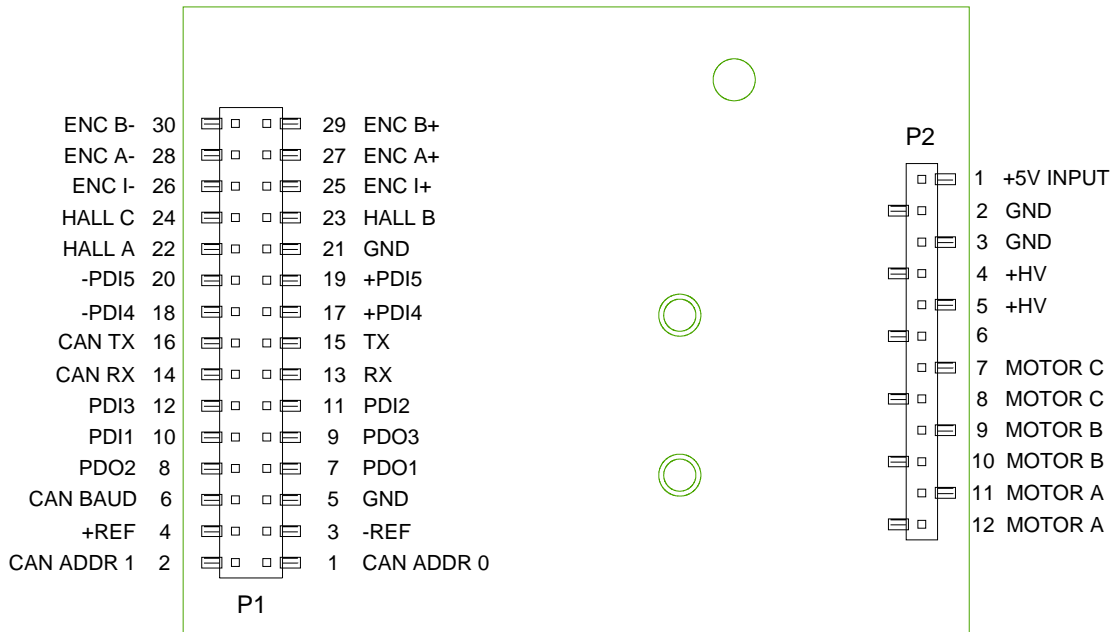

**MOUNTING DIMENSIONS**

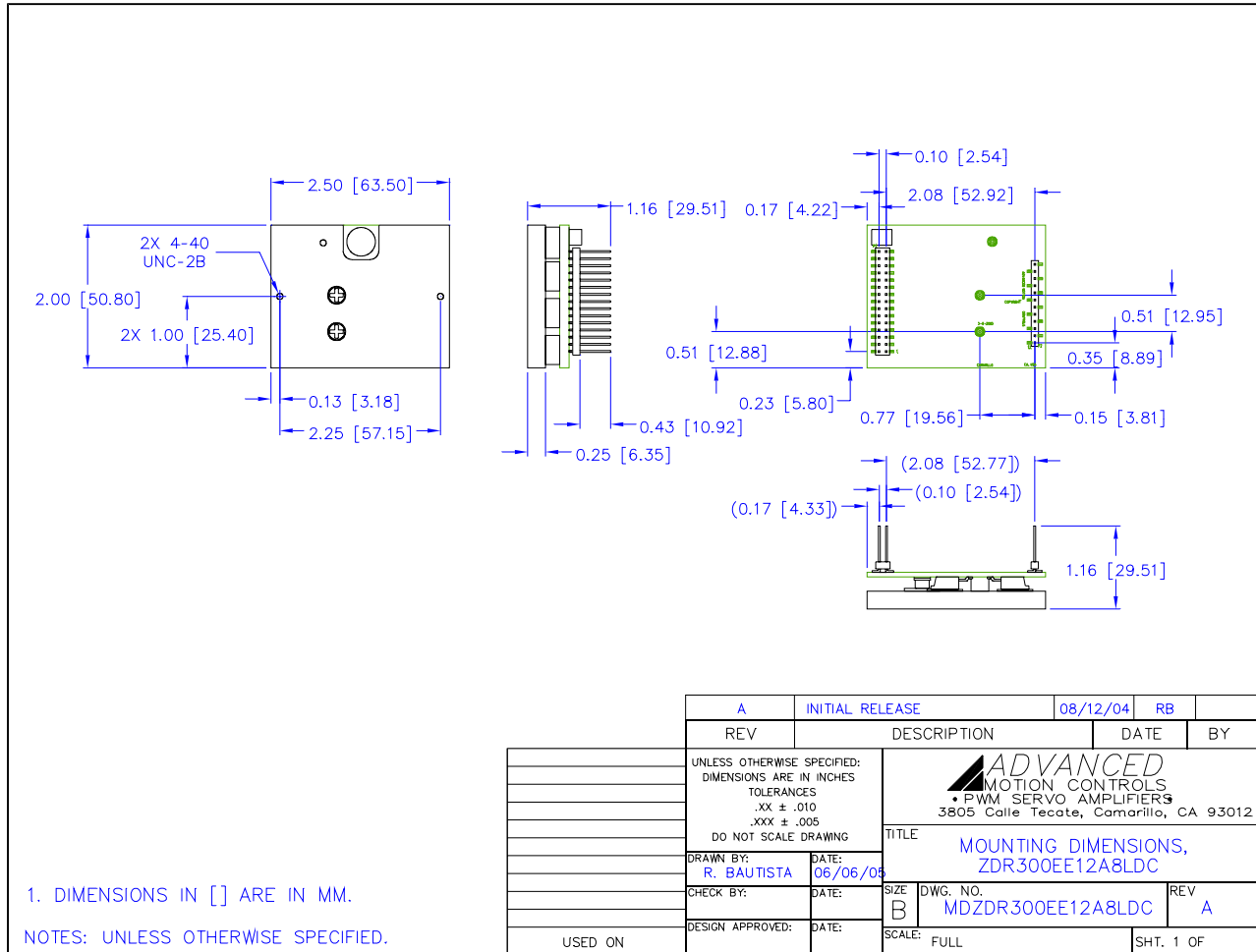

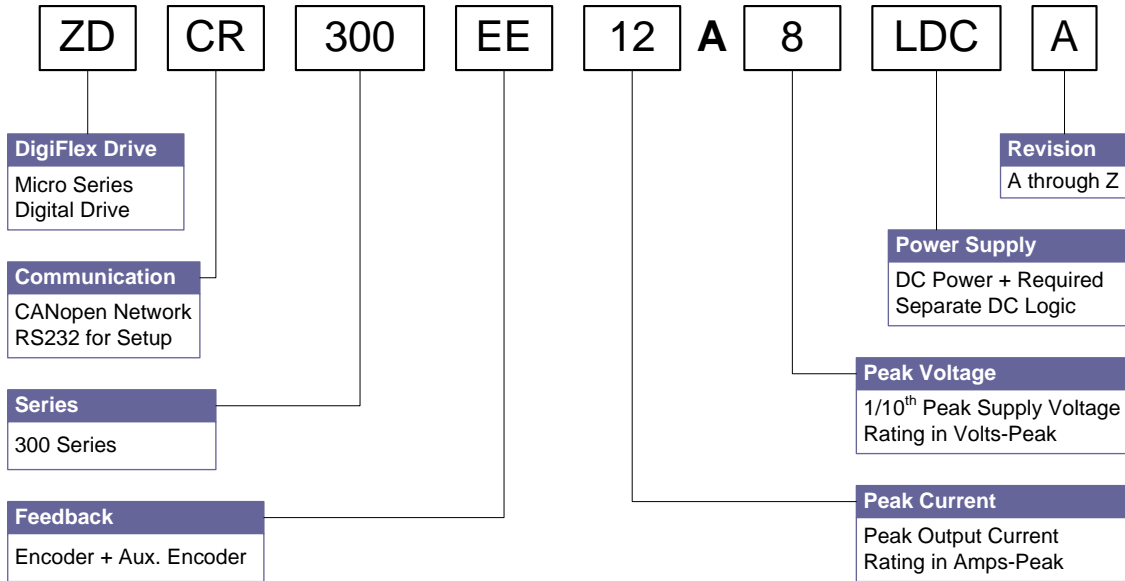

**ORDERING INFORMATION**

**Notes:**
*Peak Current*

Maximum continuous current rating is approximately 1/2 of the peak current rating.

*Revision*

This letter is not required when placing an order.  
Some letters are skipped when assigning revisions.

*Additional Options*

Only available on select drives. Options not listed here are for custom drives. Contact an AMC representative for more information.

Drive Family	Available Accessories	Accessory Part Numbers
ZDCR300EE12A8LDC	Mounting Card	MC1XZDCR
	Shunt Regulator	SRST50
		SRST70
		SRST80
	Filter Card	BFC1010
		BFC10010
	Power Supply	PS16L30 / PS16H30
		PS16L36 / PS16H36
		PS16L40 / PS16H40
		PS16L60 / PS16H60
		PS16L72 / PS16H72
		PS16L80 / PS16H80
		PS2X3H24 / PS2X3W24
		PS2X3H48 / PS2X3W48
		PS300H24 / PS300W24
PS300H48 / PS300W48		