

Description

The S100A40AC PWM servo drive is designed to drive three phase brushless motors with sine wave current at a high switching frequency. The drive requires two sinusoidal command signals with a 120-degree phase shift (external commutation). The phase angle must correspond to the position of the motor rotor, while the signal amplitude controls the motor torque. The S100A40AC interfaces directly with digital controllers. The drive is fully protected against over-voltage, over-current, over-heating, and short-circuits, and requires only a three-phase AC power supply. A red/green LED and two digital outputs indicate operating status. All signal inputs and outputs are optically isolated from the power section to eliminate the need for a transformer coupled power supply.

Power Range

Peak Current	100 A (70.7 A _{RMS})
Continuous Current	50 A _{RMS}
Supply Voltage	45 - 270 VAC



Features

- ▲ Four Quadrant Regenerative Operation
- ▲ Adjustable Current Limits
- ▲ Differential Input Command
- ▲ Selectable Inhibit/Enable Logic
- ▲ Digital Fault Output Monitor
- ▲ Sinusoidal Current Output
- ▲ Built in Shunt Regulator Circuit
- ▲ Adjustable Input Gain
- ▲ DIP Switch Selectable Tuning
- ▲ Drive Status LED
- ▲ Current Monitor Output
- ▲ No Crossover Distortion
- ▲ Built-in brake/shunt regulator
- ▲ Internal brake/shunt resistor

MODES OF OPERATION

- Current

COMMAND SOURCE

- 120° Sine



COMPLIANCES & AGENCY APPROVALS

- UL
- cUL
- CE Class A (LVD)
- CE Class A (EMC)
- RoHS

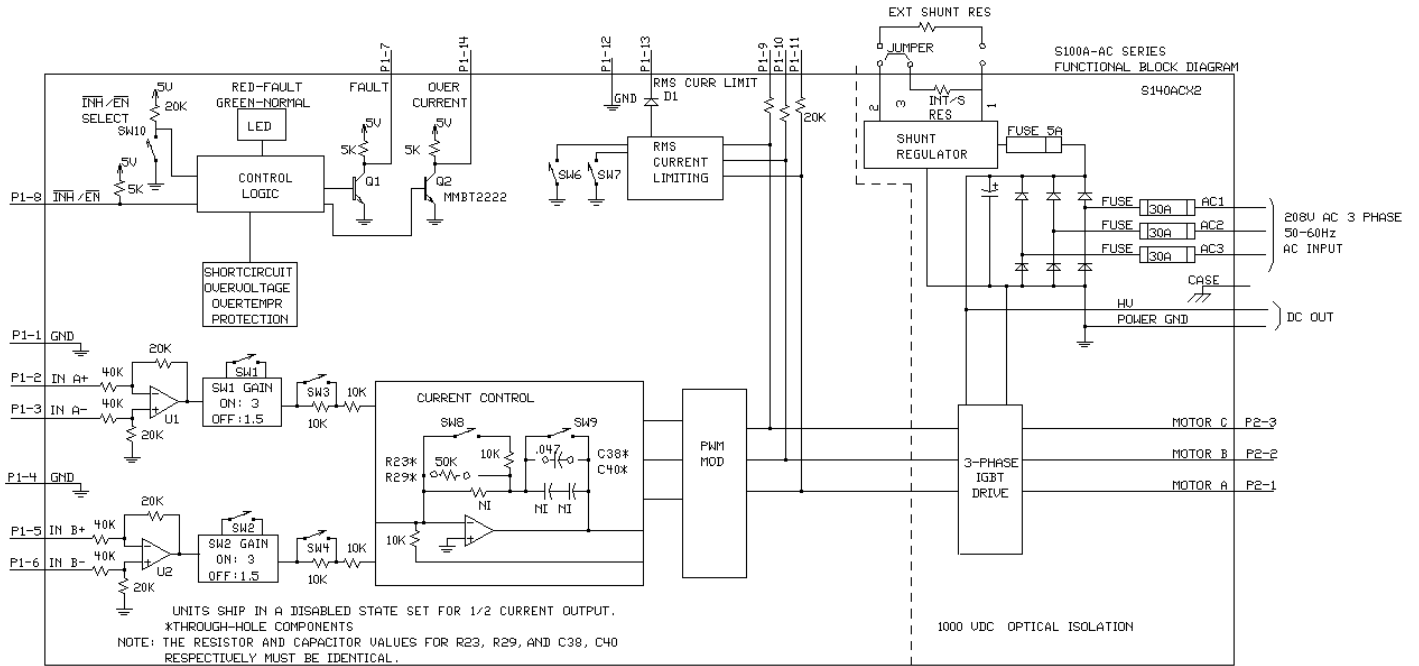
BLOCK DIAGRAM



Information on Approvals and Compliances

	<p>US and Canadian safety compliance with UL 508c, the industrial standard for power conversion electronics. UL registered under file number E140173. Note that machine components compliant with UL are considered UL registered as opposed to UL listed as would be the case for commercial products.</p>
	<p>Compliant with European CE for both the Class A EMC Directive 2004/108/EC on Electromagnetic Compatibility (specifically EN 61000-6-4:2007 and EN 61000-6-2:2005) and LVD requirements of directive 2006/95/EC (specifically EN 60204-1:2006), a low voltage directive to protect users from electrical shock.</p>
	<p>RoHS (Reduction of Hazardous Substances) is intended to prevent hazardous substances such as lead from being manufactured in electrical and electronic equipment.</p>

SPECIFICATIONS

Description	Power Specifications	
	Units	Value
AC Supply Voltage Range	VAC	45 - 270
DC Supply Voltage Range	VDC	60 – 400
DC Bus Over Voltage Limit	VDC	425
DC Bus Under Voltage Limit	VDC	54
Maximum Peak Output Current ¹	A	100
Maximum Continuous Sine Wave Current	Arms	50
Maximum Continuous Output Power	W	19000
Maximum Power Dissipation at Continuous Current	W	1000
Internal Bus Capacitance	µF	2640
Internal Shunt Resistance	Ω	20
Internal Shunt Resistor Power Rating	W	180
Internal Shunt Resistor Turn-on Voltage	VDC	390
Minimum Load Inductance (Line-To-Line) ²	µH	600
Switching Frequency	kHz	15
Shunt Fuse	A	5
Bus Fuse	A	30

Description	Control Specifications	
	Units	Value
Command Sources	-	120° Sine
Commutation Methods	-	Sinusoidal
Modes of Operation	-	Current
Motors Supported	-	Three Phase (Brushless)
Hardware Protection	-	Over Current, Over Temperature, Over Voltage, Short Circuit (Phase-Phase & Phase-Ground)
Primary I/O Logic Level	-	5V TTL
Internal Shunt Regulator	-	Yes
Internal Shunt Resistor	-	Yes

Description	Mechanical Specifications	
	Units	Value
Agency Approvals	-	CE Class A (EMC), CE Class A (LVD), cUL, RoHS, UL
Size (H x W x D)	mm (in)	270.5 x 233.7 x 160.6 (10.6 x 9.2 x 6.3)
Weight	g (oz)	6660 (234.9)
Heatsink (Base) Temperature Range ³	°C (°F)	0 - 65 (32 - 149)
Storage Temperature Range	°C (°F)	-40 - 85 (-40 - 185)
Form Factor	-	Panel Mount
C1 Connector	-	5-contact, 11.10 mm spaced, tri-barrier terminal block
C2 Connector	-	5-contact, 11.10 mm spaced, tri-barrier terminal block
P1 Connector	-	15-pin, female D-sub
P2 Connector	-	3-contact, 11.10 mm spaced, dual-barrier terminal block

Notes

1. Maximum duration of peak current is ~2 seconds.
2. Lower inductance is acceptable for bus voltages well below maximum. Use external inductance to meet requirements.
3. Additional cooling and/or heatsink may be required to achieve rated performance.

PIN FUNCTIONS

C1 - Power Connector			
Pin	Name	Description / Notes	I/O
1	AC1	AC Supply Input (Single Or Three Phase)	I
2	AC2		I
3	AC3		I
4	NC	Not Connected (Reserved)	-
5	CASE GND	Case Ground	PE

C2 - Power Connector			
Pin	Name	Description / Notes	I/O
1	EXT SHUNT RES	External Shunt Resistor Connection. Connect resistor between this port and Shunt Resistor DC+.	-
2	SHUNT RES DC+	Shunt Resistor DC+. Connection for shunt resistor.	-
3	INT SHUNT RES	Internal Shunt Resistor. Jumper to Shunt Resistor DC+ to activate.	-
4	HIGH VOLTAGE	DC Bus Output	O
5	POWER GND		PGND

P1 - Signal Connector			
Pin	Name	Description / Notes	I/O
1	SIGNAL GND	Signal Ground	SGND
2	+REF-IN-A	Differential reference input, maximum ± 10 V, 40K input resistance	I
3	-REF-IN-A		I
4	SIGNAL GND	Signal Ground	SGND
5	+REF-IN-B	Differential reference input, maximum ± 10 V, 40K input resistance	I
6	-REF-IN-B		I
7	FAULT OUT	TTL level (+5 V) output becomes high when power devices are disabled due to at least one of the following conditions: inhibit, output short circuit, over voltage, over temperature, power-up reset.	O
8	INHIBIT/ENABLE IN	TTL level (+5 V) inhibit/enable input. Pull to ground to enable drive (SW10-OFF). Pull to ground to inhibit drive (SW10-ON). Inhibit turns off all power devices.	I
9	CURR MONITOR A OUT	Phase Current Monitor. 7.25 V = amplifier peak rated current .	O
10	CURR MONITOR B OUT		O
11	CURR MONITOR C OUT		O
12	SIGNAL GND	Signal Ground	SGND
13	RMS CURRENT LIMIT	The RMS current limit can be controlled by an external voltage; 5 V = maximum RMS current limit. This is referenced to Signal Ground. No input to this pin is necessary to obtain maximum current.	I
14	OVER-CURRENT FALUT OUT	This transistor output becomes high if RMS current (in any phase) exceeds RMS current limit. This creates a fault condition. Drive will re-enable when the RMS current returns to values within the RMS current limit range.	I
15	NC	Not Connected (Reserved)	-

P2 - Motor Power Connector			
Pin	Name	Description / Notes	I/O
1	MOTOR A	Motor Phase A	O
2	MOTOR B	Motor Phase B	O
3	MOTOR C	Motor Phase C	O

HARDWARE SETTINGS

Switch Functions

Switch	Description	Setting	
		On	Off
1	Input range selection. Input range can be set to ± 5 V or ± 10 V. Must be set the same as switch 2.	± 5 V	± 10 V
2	Input range selection. Input range can be set to ± 5 V or ± 10 V. Must be set the same as switch 1.	± 5 V	± 10 V
3	Peak Current Limit. Sets the peak current limit to 50% or 100% of the maximum peak current. Must be set the same as switch 4.	100%	50%
4	Peak Current Limit. Sets the peak current limit to 50% or 100% of the maximum peak current. Must be set the same as switch 3.	100%	50%
5	Reserved Function	-	-
6	Bit 0 of binary value for RMS current limit setting. See details below.	1	0
7	Bit 1 of binary value for RMS current limit setting. See details below.	1	0
8	Current loop proportional gain adjustment. ON by default.	Decrease	Increase
9	Current loop integral gain. Activates or deactivates integration. OFF by default.	Inactive	Active
10	Inhibit logic. Sets the logic level of inhibit pins.	Active Low	Active High

Additional Details

Switches 1 & 2, and switches 3 & 4 must be set the same. Switches 6 and 7 can be used to reduce the continuous current limit to a percentage given in the table below. 100% means no reduction.

% Of Maximum Continuous Current Limit	Switch 6	Switch 7
25	OFF	OFF
50	ON	OFF
100	OFF	ON
	ON	ON

Through-hole Components[†]

Location	Description
C38*	Current Loop Integrator. Three identical through-hole capacitors that can be added for more precise current loop tuning. See section below on Tuning with Through-hole components for more details.
C40*	
R23*	Current Loop Proportional Gain. Three identical through-hole resistors that can be added for more precise current loop tuning. See section below on Tuning with Through-hole components for more details.
R29*	

Tuning With Through-hole Components

In general, the drive will not need to be further tuned with through-hole components. However, for applications requiring more precise tuning than what is offered by the potentiometers and dipswitches, the drive can be manually modified with through-hole resistors and capacitors as denoted in the above table. By default, the through-hole locations are not populated when the drive is shipped. Before attempting to add through-hole components to the board, consult the section on loop tuning in the installation notes on the manufacturer's website. Some general rules of thumb to follow when adding through-hole components are:

- A larger resistor value will increase the proportional gain, and therefore create a faster response time.
- A larger capacitor value will increase the integration time, and therefore create a slower response time.

Proper tuning using the through-hole components will require careful observation of the loop response on a digital oscilloscope to find the optimal through-hole component values for the specific application.

[†]Note: Damage done to the drive while performing these modifications will void the warranty.

MECHANICAL INFORMATION

C1 - Power Connector

Connector Information		5-contact, 11.10 mm spaced, tri-barrier terminal block
Mating Connector	Details	Not applicable
	Included with Drive	Not applicable

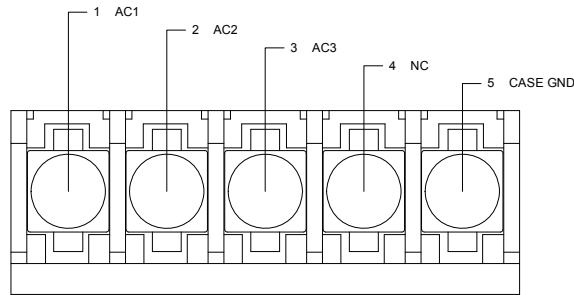

C2 - Power Connector

Connector Information		5-contact, 11.10 mm spaced, tri-barrier terminal block
Mating Connector	Details	Not applicable
	Included with Drive	Not applicable

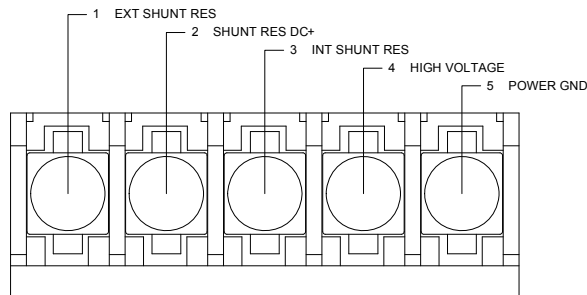

P1 - Signal Connector

Connector Information		15-pin, female D-sub
Mating Connector	Details	TYCO: Plug P/N 205206-3; Housing P/N 5745172-1; Terminals P/N 1658540-5 (loose) or 1658540-4 (strip)
	Included with Drive	No

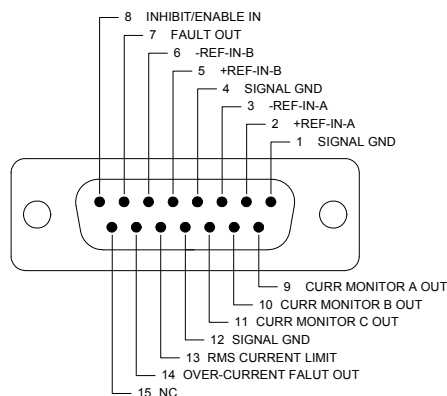

P2 - Motor Power Connector

Connector Information		3-contact, 11.10 mm spaced, dual-barrier terminal block
Mating Connector	Details	Not applicable
	Included with Drive	Not applicable

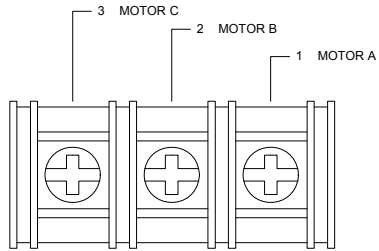

PART NUMBERING INFORMATION

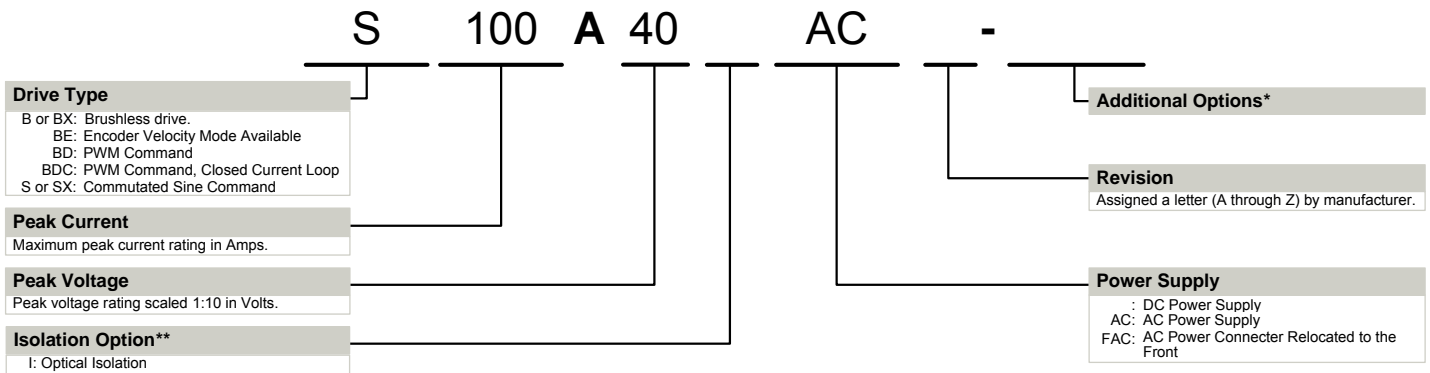

* Options available for orders with sufficient volume. Contact *ADVANCED* Motion Controls for more information.
 ** Isolation comes standard on all AC supply drives and most DC supply drives 200V and above. Consult selection tables of the website or drive datasheet block diagram to see if isolation is included.

ADVANCED Motion Controls analog series of servo drives are available in many configurations. Note that not all possible part number combinations are offered as standard drives. All models listed in the selection tables of the website are readily available, standard product offerings.

ADVANCED Motion Controls also has the capability to promptly develop and deliver specified products for OEMs with volume requests. Our Applications and Engineering Departments will work closely with your design team through all stages of development in order to provide the best servo drive solution for your system. Equipped with on-site manufacturing for quick-turn customs capabilities, *ADVANCED* Motion Controls utilizes our years of engineering and manufacturing expertise to decrease your costs and time-to-market while increasing system quality and reliability.

Examples of Modifications and Customized Products

- ▲ Integration of Drive into Motor Housing
- ▲ Mount OEM PCB onto Drive Without Cables
- ▲ Multi-axis Configuration for Compact System
- ▲ Custom PCB and Baseplate for Optimized Footprint
- ▲ RTV/Epoxy Components for High Vibration
- ▲ OEM Specified Connectors for Instant Compatibility
- ▲ OEM Specified Silkscreen for Custom Appearance
- ▲ Increased Thermal Limits for High Temp. Operation
- ▲ Integrate OEM Circuitry onto Drive PCB
- ▲ Custom Control Loop Tuned to Motor Characteristics
- ▲ Custom I/O Interface for System Compatibility
- ▲ Preset Switches and Pots to Reduce User Setup
- ▲ Optimized Switching Frequency
- ▲ Ramped Velocity Command for Smooth Acceleration
- ▲ Remove Unused Features to Reduce OEM Cost
- ▲ Application Specific Current and Voltage Limits

Feel free to contact Applications Engineering for further information and details.

All specifications in this document are subject to change without written notice. Actual product may differ from pictures provided in this document.