

S100A SERIES THREE PHASE SINUSOIDAL BRUSHLESS SERVO AMPLIFIERS

Models: S100A20, S100A40

FEATURES:

- Surface-mount technology
- Small size, low cost, ease of use
- Optical isolation, see block diagram
- Sinusoidal drive and current control
- Four quadrant regenerative operation
- Agency approval:



BLOCK DIAGRAM:

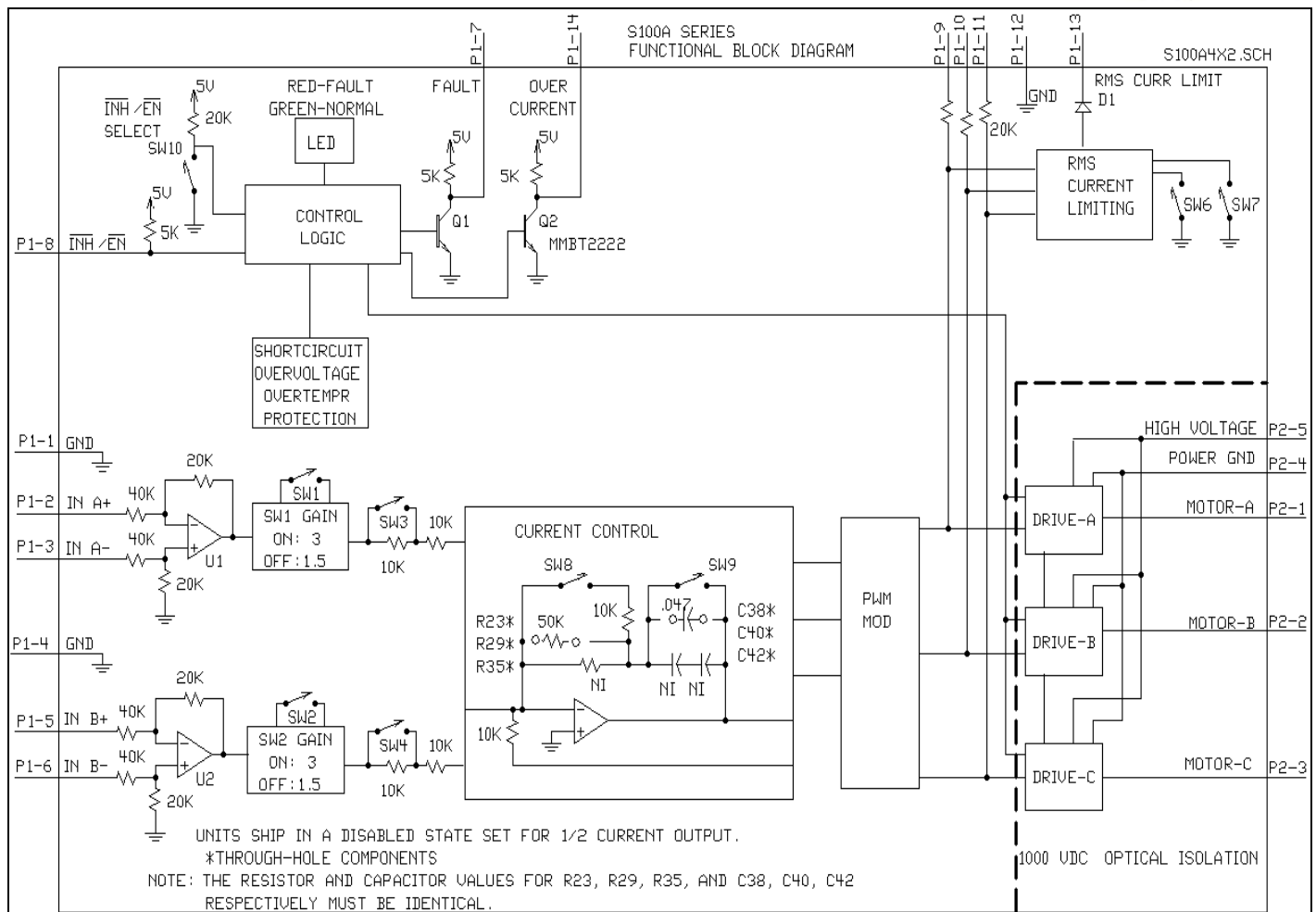

DESCRIPTION: S100A Series PWM servo amplifiers are designed to drive three phase brushless motors with sine wave current at a high switching frequency. They require two sinusoidal command signals with a 120-degree phase shift. The phase angle must correspond to the position of the motor rotor, and the signal amplitude controls the motor torque. All models interface directly with digital controllers. The amplifiers are fully protected against over-voltage, under-voltage, over-current, over-heating, and short-circuits. The S100A Series amplifiers require only a single unregulated DC power supply (all logic and control voltages are generated internally). A red/green LED and two digital outputs indicate operating status. All signal inputs and outputs are optically isolated from the power section to eliminate the need for a transformer coupled power supply.

SPECIFICATIONS:

POWER STAGE SPECIFICATIONS	MODEL	
	S100A20	S100A40
DC SUPPLY VOLTAGE	60 - 190 V	100 - 400 V
PEAK CURRENT (2 sec. max., internally limited)	± 100 A (70.7Arms)	± 100 A (70.7Arms)
MAX. CONT. CURRENT (internally limited)	± 50 A (35.4 Arms)	± 50 A (35.4 Arms)
MINIMUM LOAD INDUCTANCE *	300 µH	600 µH
SWITCHING FREQUENCY	15 kHz ± 15 %	
HEATSINK (BASE) TEMPERATURE RANGE	0° to +65° C, disables if >65° C	
POWER DISSIPATION AT CONTINUOUS CURRENT	500 W	1000 W
OVER-VOLTAGE SHUT-DOWN (self-reset)	195 V	415 V
UNDER-VOLTAGE SHUT-DOWN (self-reset)	55 V	90 V
BANDWIDTH (load dependent)	2.5 kHz	

MECHANICAL SPECIFICATIONS	
POWER CONNECTOR: P2	Screw terminals
SIGNAL CONNECTOR: P1	P1 is a 15 pin female D-sub connector
SIZE	10.65 x 9.20 x 3.64 inches 270.5 x 234 x 92.4 mm
WEIGHT	11.00 lb. 4.99 kg

* Low inductance motors require external inductors.

PIN FUNCTIONS:

CONNECTOR	PIN	NAME	DESCRIPTION / NOTES	I/O
P1	1	GND	Signal ground	SGND
	2	+REF-IN-A	Differential reference input, maximum ± 15 V, 40K input resistance	I
	3	-REF-IN-A		
	4	GND	Signal ground	SGND
	5	+REF-IN-B	Differential reference input, maximum ± 15 V, 40K input resistance	I
	6	-REF-IN-B		
	7	FAULT	This transistor output becomes high during output short circuit, over-voltage, under-voltage, over temperature, inhibit, and during power-on reset. A red LED also indicates a fault condition.	O
	8	INHIBIT / ENABLE	This TTL level input signal turns off all power devices of the "H" bridge when pulled to ground with SW10=ON. If SW10 = OFF pulling this pin to ground will enable the amplifier. This inhibit will cause a fault condition and a red LED.	I
	9	CURR MONITOR A	This monitors the input signal, connected directly to the internal current amplifier; 7.25 V = maximum peak set current.	O
	10	CURR MONITOR B		
	11	CURR MONITOR C		
	12	GND	Signal ground	SGND
	13	RMS CURRENT LIMIT	The RMS current limit can be controlled by an external voltage 5 V = maximum RMS current limit. This is referenced to P1-1. No input to this pin is necessary to obtain maximum current.	I
	14	OVER CURRENT	This transistor output becomes high if RMS current (in any phase) exceeds RMS current limit.	O
	15		Reserved	
P2	1	MOTOR A	Motor phase A connection	O
	2	MOTOR B	Motor phase B connection	O
	3	MOTOR C	Motor phase C connection	O
	4	POWER GND	Power ground	PGND
	5	HIGH VOLTAGE	DC power input	I

SWITCH FUNCTIONS:

SWITCH	FUNCTION DESCRIPTION	SETTING	
		ON	OFF
1	Input range selection*	Input range ± 5 V ± 5 V = Max. current when SW1, 2 = ON	Input range ± 10 V ± 10 V = Max. current when SW1, 2 = OFF
2			
3	Peak current limit**	The peak current limit equals 100% of maximum peak current when SW3, 4, 5 = ON.	The peak current limit equals 50% of maximum peak current when SW3, 4, 5 = OFF.
4			
5			
6	RMS current limit	SEE TABLE 1	
7			
8	Current loop gain***	Decrease	Increase
9	Current loop integrator***	Recommended setting is OFF.	
10	INHIBIT/ENABLE SELECT	P1-8 : INHIBIT With SW10=ON, pull P1-8 to ground to inhibit the amplifier.	P1-8 : ENABLE With SW10=OFF, pull P1-8 to ground to enable the amplifier.

* Switches 1 and 2 must be set the same.

** Switches 3 and 4 must be set the same.

*** See item "6.3 Current Loop Adjustments" in section G for more information.

Units are shipped set for $\frac{1}{2}$ current output via SW3, SW4 and SW5=off and in the disabled state via SW10=off.

TABLE 1

SW6	SW7	PERCENTAGE OF MAXIMUM CONTINUOUS CURRENT
ON	ON	100%
OFF	ON	100%
ON	OFF	50%
OFF	OFF	25%

CURRENT LIMIT:

Current limiting for each motor winding is independent. The peak current is maintained for two seconds. If the RMS value of the winding current exceeds the RMS current limit the amplifier shuts off. The shut off condition is indicated by high OVER CURRENT, high FAULT signal, and blinking red LED. The amplifier will re-enable when the RMS current returns to values within the RMS current limit range.

INPUT SIGNAL ISOLATION:

All pins on P1 are optically isolated (1000 V) from P2.

ORDERING INFORMATION:

Models: S100A40X, S100A20X

X indicates the current revision letter.

TYPICAL SYSTEM WIRING: See section "G".

MOUNTING DIMENSIONS: See page F-20.