

Description	Power Range
-------------	-------------

The DZCANTE-012L080 digital servo drive is designed to drive brushed and brushless servomotors from a compact form factor ideal for embedded applications. This fully digital drive operates in torque, velocity, or position mode and employs Space Vector Modulation (SVM), which results in higher bus voltage utilization and reduced heat dissipation compared to traditional PWM. The drive can be configured for a variety of external command signals. Commands can also be configured using the drive's built-in Motion Engine, an internal motion controller used with distributed motion applications. In addition to motor control, this drive features dedicated and programmable digital and analog inputs and outputs to enhance interfacing with external controllers and devices.

The DZCANTE-012L080 features a single RS232 interface used for drive configuration and setup. Drive commissioning is accomplished using DriveWare® 7, available for download at [www.a-m-c.com](http://www.a-m-c.com). The CANopen interface can be used for online operation in networked applications.

All drive and motor parameters are stored in non-volatile memory.

Peak Current	12 A (8.5 A <sub>RMS</sub> )
Continuous Current	6 A (4.2 A <sub>RMS</sub> )
Supply Voltage	20 - 80 VDC



Features
----------

- |  |   |
|--|---|
| <ul style="list-style-type: none"> <li>▲ Four Quadrant Regenerative Operation</li> <li>▲ Space Vector Modulation (SVM) Technology</li> <li>▲ Fully Digital State-of-the-art Design</li> <li>▲ Programmable Gain Settings</li> <li>▲ Fully Configurable Current, Voltage, Velocity and Position Limits</li> </ul> | <ul style="list-style-type: none"> <li>▲ PIDF Velocity Loop</li> <li>▲ PID + FF Position Loop</li> <li>▲ Compact Size, High Power Density</li> <li>▲ 12-bit Analog to Digital Hardware</li> <li>▲ On-the-Fly Mode Switching</li> <li>▲ On-the-Fly Gain Set Switching</li> </ul> |
|--|---|

**MODES OF OPERATION**

- Profile Current
- Profile Velocity
- Profile Position
- Cyclic Synchronous Current Mode
- Cyclic Synchronous Velocity Mode
- Cyclic Synchronous Position Mode

**COMMAND SOURCE**

- ±10 V Analog
- PWM and Direction
- Encoder Following
- Over the Network
- Indexing
- Jogging

**FEEDBACK SUPPORTED**

- Halls
- Incremental Encoder
- Auxiliary Incremental Encoder

**INPUTS/OUTPUTS**

- 2 High Speed Captures
- 1 Programmable Analog Input (12-bit Resolution)
- 2 Programmable Digital Inputs (Differential)
- 3 Programmable Digital Inputs (Single-Ended)
- 3 Programmable Digital Outputs (Single-Ended)

**COMPLIANCES & AGENCY APPROVALS**

- UL
- cUL
- CE Class A (LVD)
- CE Class A (EMC)
- RoHS

**BLOCK DIAGRAM**

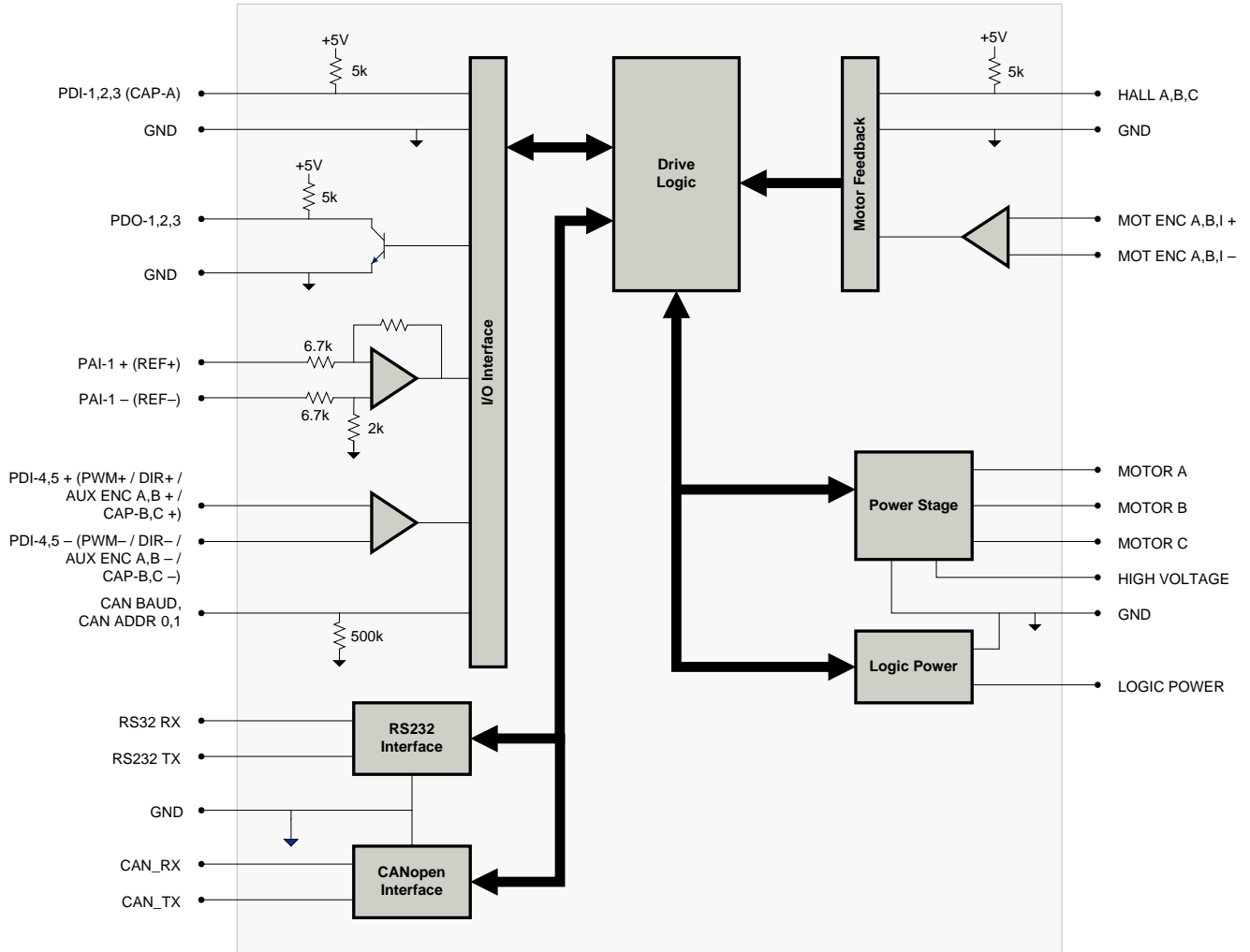

**Information on Approvals and Compliances**



US and Canadian safety compliance with UL 508c, the industrial standard for power conversion electronics. UL registered under file number E140173. Note that machine components compliant with UL are considered UL registered as opposed to UL listed as would be the case for commercial products.



Compliant with European CE for both the Class A EMC Directive 2004/108/EC on Electromagnetic Compatibility (specifically EN 61000-6-4:2007 and EN 61000-6-2:2005) and LVD requirements of directive 2006/95/EC (specifically EN 60204-1:2006), a low voltage directive to protect users from electrical shock.



RoHS (Reduction of Hazardous Substances) is intended to prevent hazardous substances such as lead from being manufactured in electrical and electronic equipment.

**SPECIFICATIONS**

Power Specifications		
Description	Units	Value
DC Supply Voltage Range	VDC	20 - 80
DC Bus Over Voltage Limit	VDC	88
DC Bus Under Voltage Limit	VDC	17
Logic Supply Voltage	VDC	5 (+/- 5%)
Maximum Peak Output Current <sup>1</sup>	A (Arms)	12 (8.5)
Maximum Continuous Output Current	A (Arms)	6 (4.2)
Maximum Continuous Output Power	W	456
Maximum Power Dissipation at Continuous Current	W	24
Internal Bus Capacitance	µF	33
Minimum Load Inductance (Line-To-Line) <sup>2</sup>	µH	250 (at 80 V supply); 150 (at 48 V supply); 75 (at 24 V supply)
Switching Frequency	kHz	20
Maximum Output PWM Duty Cycle	%	85
Control Specifications		
Description	Units	Value
Communication Interfaces	-	CANopen (RS-232 for configuration)
Command Sources	-	±10 V Analog, Encoder Following, Over the Network, PWM and Direction, Indexing, Jogging
Feedback Supported	-	Auxiliary Incremental Encoder, Halls, Incremental Encoder
Commutation Methods	-	Sinusoidal, Trapezoidal
Modes of Operation	-	Profile Current, Profile Velocity, Profile Position, Cyclic Synchronous Current Mode, Cyclic Synchronous Velocity Mode, Cyclic Synchronous Position Mode
Motors Supported	-	Closed Loop Vector, Single Phase (Brushed, Voice Coil, Inductive Load), Three Phase (Brushless)
Hardware Protection	-	40+ Configurable Functions, Over Current, Over Temperature (Drive & Motor), Over Voltage, Short Circuit (Phase-Phase & Phase-Ground), Under Voltage
Programmable Digital Inputs/Outputs (PDIs/PDOs)	-	5/3
Programmable Analog Inputs/Outputs (PAIs/PAOs)	-	1/0
Primary I/O Logic Level	-	5V TTL
Current Loop Sample Time	µs	50
Velocity Loop Sample Time	µs	100
Position Loop Sample Time	µs	100
Maximum Encoder Frequency	MHz	20 (5 pre-quadrature)
Mechanical Specifications		
Description	Units	Value
Agency Approvals	-	CE Class A (EMC), CE Class A (LVD), cUL, RoHS, UL
Size (H x W x D)	mm (in)	63.5 x 50.8 x 18.4 (2.5 x 2 x 0.7)
Weight	g (oz)	99.8 (3.5)
Heatsink (Base) Temperature Range <sup>3</sup>	°C (°F)	0 - 65 (32 - 149)
Storage Temperature Range	°C (°F)	-40 - 85 (-40 - 185)
Cooling System	-	Natural Convection
Form Factor	-	PCB Mounted
P1 Connector	-	30-pin, 2.54 mm spaced, dual-row header
P2 Connector	-	12-pin, 2.54 mm spaced header

**Notes**

1. Capable of supplying drive rated peak current for 2 seconds with 10 second foldback to continuous value. Longer times are possible with lower current limits.
2. Lower inductance is acceptable for bus voltages well below maximum. Use external inductance to meet requirements.
3. Additional cooling and/or heatsink may be required to achieve rated performance.

**PIN FUNCTIONS**

P1 - Signal Connector			
Pin	Name	Description / Notes	I/O
1	CAN ADDR 0	CAN Bus Address Selector	I
2	CAN ADDR 1		I
3	PAI-1 + (REF+)	Differential Programmable Analog Input or Reference Signal Input (12-bit Resolution)	I
4	PAI-1 - (REF-)		I
5	GND	Ground	GND
6	CAN BAUD	CAN bus bit rate selector.	I
7	PDO-1	Programmable Digital Output	O
8	PDO-2	Programmable Digital Output	O
9	PDO-3	Programmable Digital Output	O
10	PDI-1	Programmable Digital Input	I
11	PDI-2	Programmable Digital Input	I
12	PDI-3 (CAP-A)	Programmable Digital Input or High Speed Capture	I
13	RS232 RX	Receive Line (RS-232)	I
14	CAN RX	CAN Receive Line (Requires External Transceiver)	I
15	RS232 TX	Transmit Line (RS-232)	O
16	CAN TX	CAN Transmit Line (Requires External Transceiver)	O
17	PDI-4 + (PWM+ / AUX ENC A+ / CAP-B+)	Programmable Digital Input or PWM or Auxiliary Encoder or High Speed Capture (For Single-Ended Signals see DZ HW Installation Manual)	I
18	PDI-4 - (PWM- / AUX ENC A- / CAP-B-)		I
19	PDI-5 + (DIR+ / AUX ENC B+ / CAP-C+)	Programmable Digital Input or Direction or Auxiliary Encoder or High Speed Capture (For Single-Ended Signals see DZ HW Installation Manual)	I
20	PDI-5 - (DIR- / AUX ENC B- / CAP-C-)		I
21	GND	Ground	GND
22	HALL A	Single-ended Commutation Sensor Input (For Differential Inputs See MC1XDZ01 Datasheet For Recommended Signal Conditioning)	I
23	HALL B		I
24	HALL C		I
25	MOT ENC I+	Differential Encoder Index Input (See MC1XDZ01 Datasheet For Recommended Signal Conditioning)	I
26	MOT ENC I-		I
27	MOT ENC A+	Differential Encoder A Channel Input (See MC1XDZ01 Datasheet For Recommended Signal Conditioning)	I
28	MOT ENC A-		I
29	MOT ENC B+	Differential Encoder B Channel Input (See MC1XDZ01 Datasheet For Recommended Signal Conditioning)	I
30	MOT ENC B-		I

P2 - Power Connector			
Pin	Name	Description / Notes	I/O
1	LOGIC PWR	Logic Supply Input	I
2	GND	Ground	GND
3	GND	Ground	GND
4	HIGH VOLTAGE	DC Power Input	I
5	HIGH VOLTAGE	DC Power Input	I
6	RESERVED	Reserved	-
7	MOTOR C	Motor Phase C	O
8	MOTOR C	Motor Phase C	O
9	MOTOR B	Motor Phase B	O
10	MOTOR B	Motor Phase B	O
11	MOTOR A	Motor Phase A	O
12	MOTOR A	Motor Phase A	O

**Pin Details**
**CAN ADDR 0 (P1-1)**

This pin, CAN ADDR 0, as well as CAN ADDR 1, are used for CAN bus addressing. To set the CAN node address of a drive, use the formula

$$CANAddress = \frac{7 * Addr0}{3} + 8 * \frac{7 * Addr1}{3}$$

where *CANAddress* is the desired node address and *Addr0* and *Addr1* represent the voltage that should be applied to pins CAN ADDR 0 and CAN ADDR 1, respectively. The values for *Addr0* and *Addr1* are always integer multiples of 3/7 V within the range 0-3 V. Examples of the voltages required to set certain node addresses are given in the table below. Note that setting a CAN address of 0 will utilize the address stored in non-volatile memory.

CAN ADDR 0 Value (V)	CAN ADDR 1 Value (V)	CAN ADDR Tolerance (V)	CAN Address (Node #)
0	0	±0.1	Address stored in non-volatile memory
3/7 (0.43)	0	±0.1	1
6/7 (0.86)	0	±0.1	2
9/7 (1.3)	0	±0.1	3
...	...	±0.1	...
18/7 (2.57)	21/7 (3.0)	±0.1	62
21/7 (3.0)	21/7 (3.0)	±0.1	63

*CAN BAUD (P1-6)*

The CAN bit rate is set by applying the appropriate voltage to the CAN BAUD pin as given in the table below.

CAN BAUD Value (V)	CAN BAUD Tolerance (V)	CAN Bus Bit Rate (bits/s)
0	±0.388	Bit rate stored in non-volatile memory
1	±0.388	500k
2	±0.388	250k
3	±0.388	125k

**MECHANICAL INFORMATION**

**P1 - Signal Connector**

Connector Information	30-pin, 2.54 mm spaced, dual-row header	
Mating Connector	Details	Samtec: SSM-115-L-DV
	Included with Drive	No

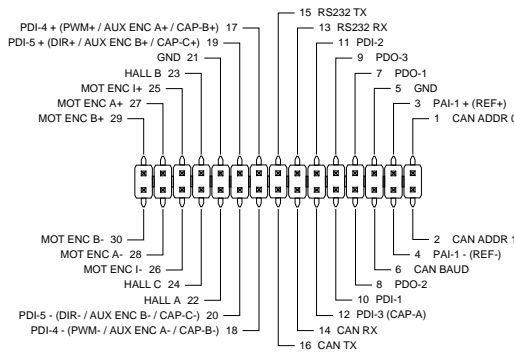

**P2 - Power Connector**

Connector Information	12-pin, 2.54 mm spaced header	
Mating Connector	Details	Samtec: BCS-112-L-S-PE
	Included with Drive	No

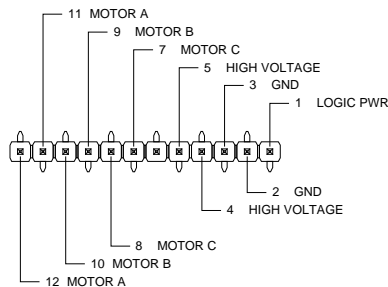



**PART NUMBERING INFORMATION**

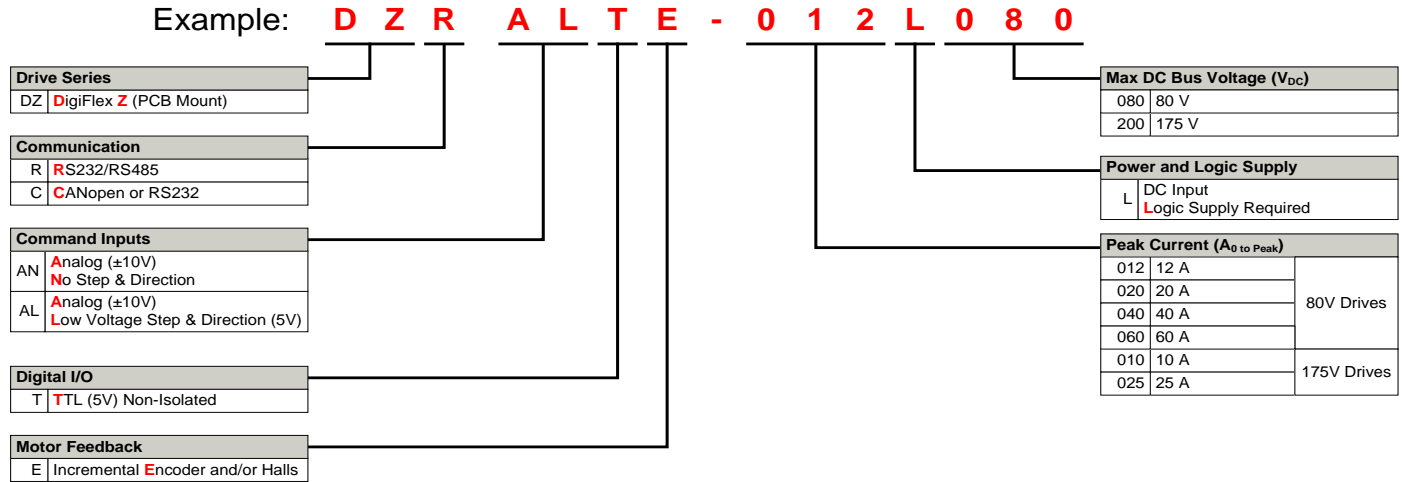

DigiFlex® Performance™ series of products are available in many configurations. Note that not all possible part number combinations are offered as standard drives. All models listed in the selection tables of the website are readily available, standard product offerings.

ADVANCED Motion Controls also has the capability to promptly develop and deliver specified products for OEMs with volume requests. Our Applications and Engineering Departments will work closely with your design team through all stages of development in order to provide the best servo drive solution for your system. Equipped with on-site manufacturing for quick-turn customs capabilities, ADVANCED Motion Controls utilizes our years of engineering and manufacturing expertise to decrease your costs and time-to-market while increasing system quality and reliability.

**Examples of Customized Products**

- ▲ Optimized Footprint
- ▲ Private Label Software
- ▲ OEM Specified Connectors
- ▲ No Outer Case
- ▲ Increased Current Resolution
- ▲ Increased Temperature Range
- ▲ Custom Control Interface
- ▲ Integrated System I/O
- ▲ Tailored Project File
- ▲ Silkscreen Branding
- ▲ Optimized Base Plate
- ▲ Increased Current Limits
- ▲ Increased Voltage Range
- ▲ Conformal Coating
- ▲ Multi-Axis Configurations
- ▲ Reduced Profile Size and Weight

Feel free to contact Applications Engineering for further information and details.

**Available Accessories**

ADVANCED Motion Controls offers a variety of accessories designed to facilitate drive integration into a servo system. Visit [www.a-m-c.com](http://www.a-m-c.com) to see which accessories will assist with your application design and implementation.

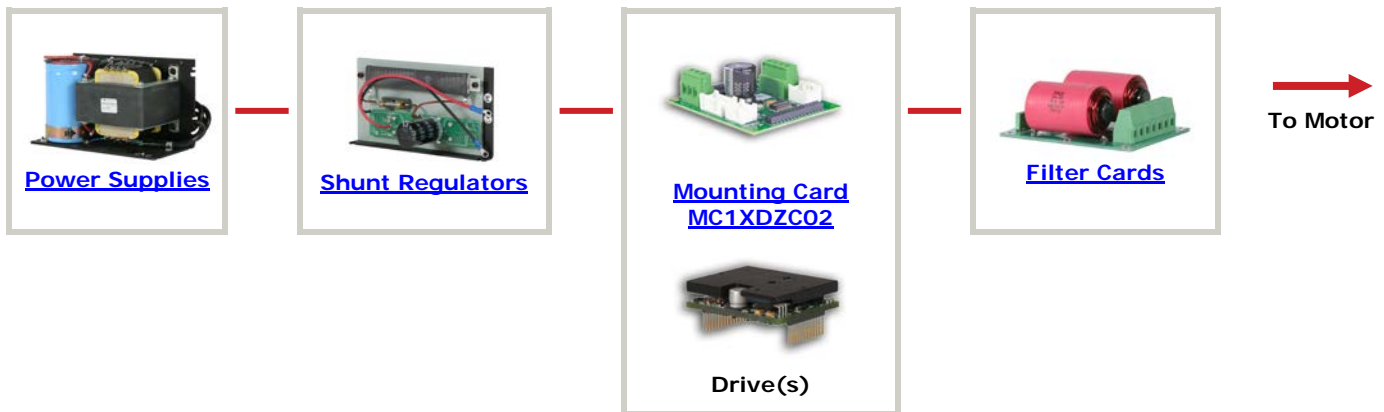

All specifications in this document are subject to change without written notice. Actual product may differ from pictures provided in this document.