

DIGIFLEX® DIGITAL SERVO DRIVES MODEL: DR101RE60A40LDC (-10, -16)

FEATURES:

- Fully digital, state-of-the-art design
- Space Vector Modulation and vector control technology
- 20kHz Digital current loop with programmable gain settings
- PIDF velocity loop with 100microsecond update rate
- PID + FF position loop with 100 microsecond update rate
- Hall sensor + encoder or encoder-only based commutation
- Surface-mount technology
- Small size, low cost, ease of use

- Isolated RS232/485 interface for setup and networking
- Windows© based setup software with built-in 8-channel digital scope
- Operates in torque, velocity or position mode with programmable gain settings
- Programmable profiling in all modes
- Fully configurable current, voltage, velocity and position limits.
- Step & direction mode for stepper replacement
- Encoder following with programmable gear ratio

- 4 isolated programmable digital inputs
- 2 programmable differential inputs, configurable as step & direction, master encoder, or secondary encoder for dual loop operation
- 4 isolated programmable digital outputs
- 2 programmable analog inputs (10-bit)
- 14-bit reference input or programmable analog input
- 1 programmable analog output (10-bit)
- Software selectable emulated encoder output resolution*

Model Number	Low	High
DR101RE	12-bit	14-bit
DR101RE... -10	10-bit	12-bit
DR101RE... -16	14-bit	16-bit

* See maximum speed table below

- Four quadrant regenerative operation
- Separate logic supply
- Bi-color LED status indicator
- Extensive built-in protection against:
 - over-voltage (programmable)
 - under-voltage (programmable)
 - short-circuit: phase-phase, phase-ground
 - over-current
 - over-temperature



BLOCK DIAGRAM:

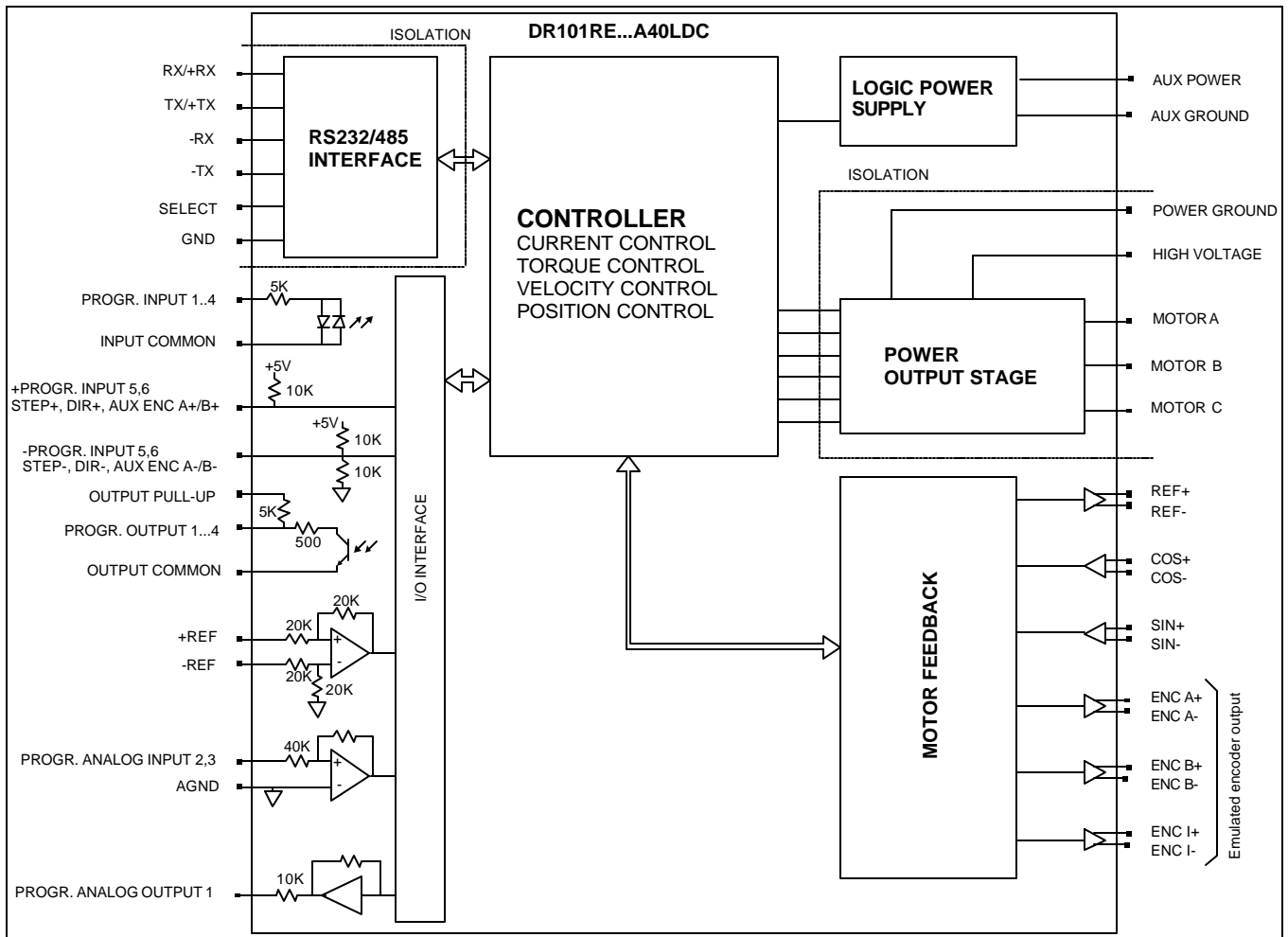

DESCRIPTION:

The DR101RE Series digital PWM servo drives are designed to drive brushed and brushless servomotors. These fully digital drives operate in torque, velocity, or position mode and employ Space Vector Modulation (SVM), which results in higher bus voltage utilization and reduced heat dissipation. The command source can be generated internally or can be supplied externally. In addition to motor control, these drives feature dedicated and programmable digital and analog inputs and outputs to enhance interfacing with external controllers and devices.

DR101RE Series drives feature a single, isolated RS232/485 interface, which is used for drive configuration and setup as well as online operation in networked applications. Drive commissioning can be accomplished through a fully graphical Windows© based application.

All drive and motor parameters are stored in non-volatile memory.

Maximum Motor Velocity

Emulated Encoder Resolution	Maximum Motor Speed*
10-bit	64000 rpm
12-bit	16000 rpm
14-bit	4000 rpm
16-bit	1000 rpm

* Assuming no other limitations limit the motor speed.

SPECIFICATIONS:

POWER STAGE SPECIFICATIONS	DR101RE60A40LDC
DC SUPPLY VOLTAGE	60...400 VDC
PEAK CURRENT	60A (42.4Arms)
MAXIMUM CONTINUOUS CURRENT	30A (21.2Arms)
MINIMUM LOAD INDUCTANCE	600 μ H
SWITCHING FREQUENCY	20 kHz
HEATSINK (BASEPLATE) TEMPERATURE RANGE	0 to 65 °C, disables at 65 °C
POWER DISSIPATION AT CONTINUOUS CURRENT	600W
MIN. UNDER VOLTAGE SHUTDOWN	60 VDC
MAX. OVER-VOLTAGE SHUTDOWN	425 VDC
LOGIC SUPPLY VOLTAGE	20...30 VDC

MECHANICAL SPECIFICATIONS	
POWER CONNECTOR:	Screw terminals
LOGIC SUPPLY CONNECTOR:	2-pin; 5.08mm pitch removable with screw flange
MOTOR FEEDBACK CONNECTOR: CN3*	15-pin high density female D-sub
I/O CONNECTOR: CN2*	26-pin high density female D-sub
COMMUNICATIONS INTERFACE (RS232/485): CN1*	9-pin female D-sub
SIZE	9.24 x 6.31 x 3.99 inches 234.7 x 160.2 x 101.3 mm
WEIGHT	

* Mating connectors are not included.

PIN FUNCTIONS:

P1 - Motor and Power Connector:

CONNECTOR	PIN	NAME	DESCRIPTION	I/O
P1	1	MA	Motor phase A	O
	2	MB	Motor phase B	O
	3	MC	Motor phase C	O
	4	POWER GND	Power ground.	GNDPWR
	5	HIGH VOLTAGE	DC power input	I

P – Logic Supply Connector:

CONNECTOR	PIN	NAME	DESCRIPTION	I/O
P	1	RTN AUX	Logic supply ground	GND
	2	PWR AUX	Logic supply power	I

CN3 - Motor Feedback Connector:

CONNECTOR	PIN	NAME	DESCRIPTION	I/O
CN3	1	N/C	Not connected	
	2	N/C	Not connected	
	3	N/C	Not connected	
	4	REF+	Resolver reference (excitation) output. 4Vrms @ 5kHz.	O
	5	REF-		O
	6	SIN+	Resolver sine input. 2Vrms	I
	7	SIN-		I
	8	COS+	Resolver cosine input. 2Vrms	I
	9	COS-		I
	10	N/C*	Not connected	
	11	N/C*	Not connected	
	12	SGND	Signal ground	SGND
	13	+5V OUT	+5V @ 250mA max. Short-circuit protected.	O
	14	PAI3	Programmable analog input, single ended, 10-bit	I
	15	N/C*	Not connected	

CN2 – I/O Connector:

CONNECTOR	PIN	NAME	DESCRIPTION	I/O
CN2	1	PDO1	Isolated programmable digital output, 24V @ 50mA max. Referenced to pin 8, Output Common.	O
	2	OUTPUT COMMON	Digital output common.	OGND
	3	PDO2	Isolated programmable digital output, 24V @ 50mA max. Referenced to pin 8, Output Common.	O
	4	+REF	Differential reference signal input, 14-bit resolution. Can also be used as programmable analog input 1.	I
	5	-REF		I
	6	PAI2	Programmable analog input	I
	7	PAO1	Programmable analog output	O
	8	OUTPUT PULL-UP	Digital output pull-up via 5K resistor.	I
	9	-PDI6	Programmable Input (see CN2-18) or Direction- or Aux Enc B-	I
	10	PDO3	Isolated programmable digital output, 24V @ 50mA max. Referenced to pin 8, Output Common.	O
	11	PDI1	Isolated programmable digital input, 24V @ 5mA max. Referenced to pin 15, Input Common.	I
	12	PDI2	Isolated programmable digital input, 24V @ 5mA max. Referenced to pin 15, Input Common.	I
	13	PDI3	Isolated programmable digital input, 24V @ 5mA max. Referenced to pin 15, Input Common.	I
	14	PDO4	Isolated programmable digital output, 24V @ 50mA max. Referenced to pin 8, Output Common.	O
	15	Input Common	Digital input common. Can also be used to pull-up digital inputs.	IGND
	16	AGND	Analog ground	AGND
	17	+PDI5	Programmable differential digital input, or Step+ or Aux Enc A+	I
	18	+PDI6	Programmable, differential digital input or Direction+ or Aux Enc B+	I
	19	PDI4	Isolated programmable digital input, 24V @ 5mA max. Referenced to pin 15, Input Common.	I
	20	Encoder Channel A+	Emulated channel A output. (10, 12, 14, or 16 bit resolution)	O
	21	Encoder Channel A-		O
	22	Encoder Channel B+	Emulated channel B output. (10, 12, 14, or 16 bit resolution)	O
	23	Encoder Channel B-		O
	24	Encoder Channel I+	Emulated index output. High when channel A and B or both low.	O
	25	Encoder Channel I-		O
	26	-PDI5	Programmable Input (See CN2-17) or Step- or Aux Enc A-	I

CN1 - Communications Interface (RS232/485):

CONNECTOR	PIN	NAME	DESCRIPTION	I/O
CN1	1	SELECT	RS232/485 selection. Pull to ground (CN1-5) for RS485.	I
	2	TX/+TX	RS232: Transmit; RS485: +TX	O
	3	RX/+RX	RS232: Receive; RS485: +RX	I
	4	N/C	Not connected	
	5	SGND	Signal ground	SGND
	6	-TX	RS485: -TX	O
	7	N/C	Not connected	
	8	-RX	RS485: -RX	I
	9	N/C	Not connected	

ORDERING INFORMATION:

Standard model: DR101RE60A40LDCX

X indicates the current revision letter.

MOUNTING DIMENSIONS:

