

## DIGIFLEX® DIGITAL SERVO DRIVES

### MODEL: DQ111EE40A8BDC

WITH **SynQNet™** INTERFACE

#### FEATURES:

- Fully digital, state-of-the-art design
- Space Vector Modulation and vector control technology
- 20kHz Digital current loop with programmable gain settings
- Hall sensor + encoder or encoder-only based sinusoidal commutation
- Surface-mount technology
- Small size, low cost, ease of use
  
- SynQNet™ motion control network interface
- Windows95/98/2000/ME/NT© based setup software for setup via SynQNet™ interface
- Operates in torque mode with programmable gain settings and current limiting
  
- 2 programmable isolated digital inputs
- 2 programmable isolated digital outputs
- Dedicated Brake and Node Alarm outputs
- 14-bit reference input or programmable analog input
- 2 high-speed differential inputs (high-speed capture, encoder input)
- 2 high-speed differential outputs (step&dir, divide-by-N)
- Dedicated, isolated node disable, positive and negative limits, and home inputs
  
- Separate logic back-up supply input
- Four quadrant regenerative operation
- Bi-color LED status indicator
- Extensive built-in protection against:
  - over-voltage (programmable)
  - under-voltage (programmable)
  - short-circuit: phase-phase, phase-ground
  - over-current
  - over-temperature

\*Picture shown without silkscreen.



**ADVANCED MOTION CONTROLS**  
 3805 Calle Tecate, Camarillo, CA 93012  
 Tel: (805) 389-1935, Fax: (805) 389-1165  
<http://www.a-m-c.com>

**BLOCK DIAGRAM:**

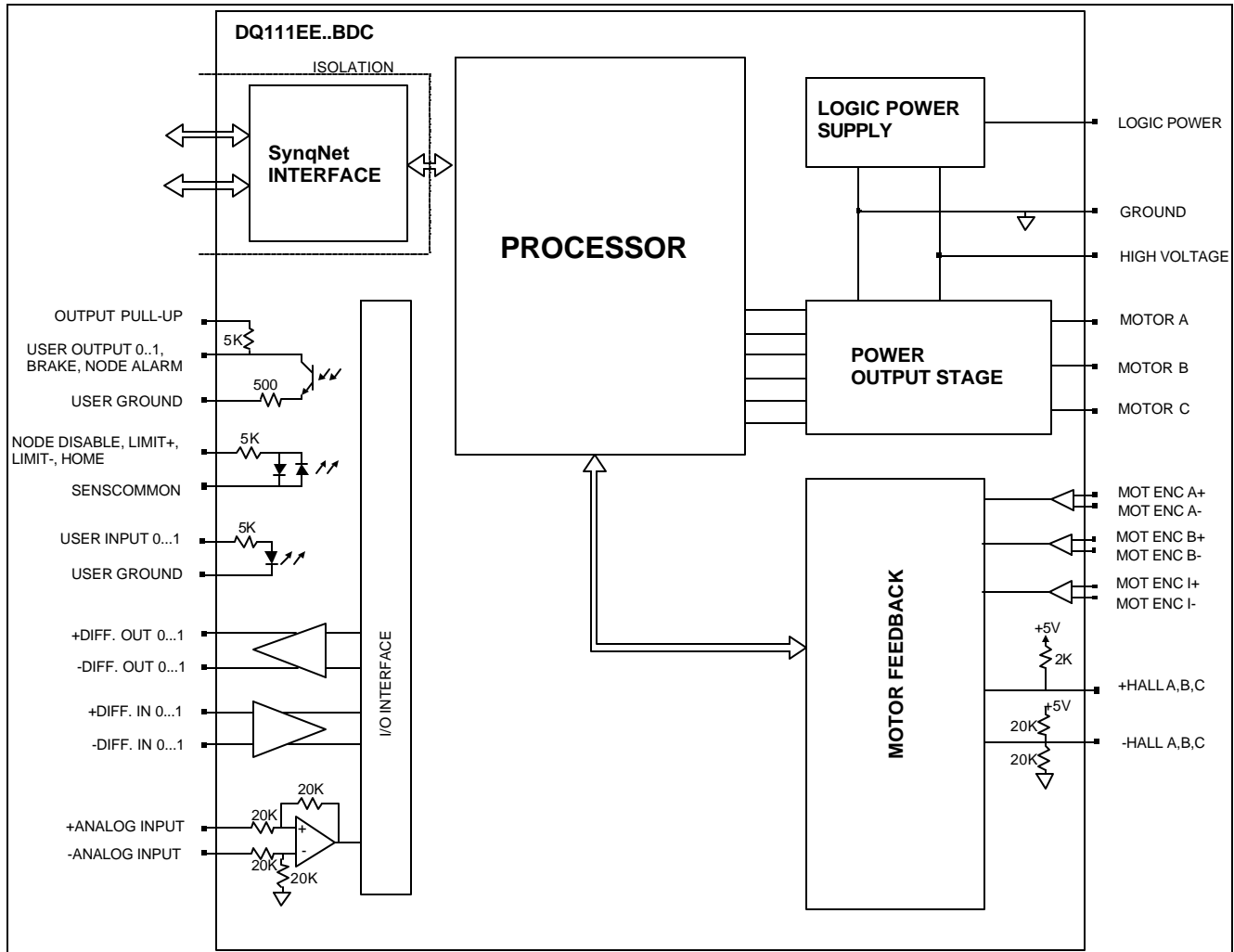

**DESCRIPTION:**

The DQ111EE Series digital PWM servo drives are designed to drive brushed and brushless servomotors. These fully digital drives operate in torque mode and employ Space Vector Modulation (SVM), which results in higher bus voltage utilization and reduced heat dissipation. The command source can be generated internally or can be supplied externally. In addition to motor control, these drives feature dedicated and programmable digital and analog inputs and outputs to enhance interfacing with external controllers and devices.

DQ111EE Series drives feature a SynqNet™ interface for high-speed digital command operation in networked applications. Drive commissioning can be accomplished through a fully graphical Windows© based application via the SynqNet interface™.

More information about SynqNet™ can be obtained at <http://www.synqnet.org>.

All drive and motor parameters are stored in non-volatile memory.

**SPECIFICATIONS:**

<b>POWER STAGE SPECIFICATIONS</b>	<b>DQ111EE40A8BDC</b>
DC SUPPLY VOLTAGE	20...80 VDC
PEAK CURRENT	40A (28.3Arms)
MAXIMUM CONTINUOUS CURRENT	20A (14.2Arms)
MINIMUM LOAD INDUCTANCE	250 $\mu$ H
SWITCHING FREQUENCY	20 kHz
HEATSINK (BASEPLATE) TEMPERATURE RANGE	0 to 65 °C, disables at 65 °C
POWER DISSIPATION AT CONTINUOUS CURRENT	100W
MIN. UNDER VOLTAGE SHUTDOWN	20 VDC
MAX. OVER-VOLTAGE SHUTDOWN	86 VDC
LOGIC SUPPLY VOLTAGE (backup supply)	20...80 VDC, 20W maximum

<b>MECHANICAL SPECIFICATIONS</b>	
MOTOR CONNECTOR: P1	Removable screw terminal
POWER CONNECTOR: P2	Removable screw terminal
MOTOR FEEDBACK CONNECTOR: CN4*	15-pin high density female D-sub
I/O CONNECTOR: CN3*	26-pin high density female D-sub
SYNQNET™ CONNECTOR: CN1, CN2*	8-pin RJ45
SIZE	7.50 x 4.40 x 1.41 inches 190.5 x 111.8 x 35.9 mm
WEIGHT	

\* Mating connectors are not included.

**PIN FUNCTIONS:**

P1 - Motor Connector:

CONNECTOR	PIN	NAME	DESCRIPTION	I/O
P1	1	MA	Motor phase A	O
	2	MB	Motor phase B	O
	3	MC	Motor phase C	O

P2 - Power Connector:

CONNECTOR	PIN	NAME	DESCRIPTION	I/O
P2	1	GND	Ground	GND
	2	HV IN	DC motor and power input. This input is used to supply power to the motor and drive logic circuitry.	I
	3	GND	Ground	GND
	4	HV AUX	Logic supply input. This input can be used to supply power to the drive logic circuitry only. Effective only when the voltage applied to pin P2-2 is lower than the voltage applied to P2-4.	I

CN4 - Motor Feedback Connector:

CONNECTOR	PIN	NAME	DESCRIPTION	I/O
CN4	1	+Hall A	Commutation sensor inputs. Internal 2K pull-up to +5VDC. Can be used with single ended or differential Hall sensors.	I
	2	+Hall B		I
	3	+Hall C		I
	4	MOT ENC A+	Differential Encoder Input. For single ended encoder signals, leave the A-terminal open.	I
	5	MOT ENC A-		I
	6	MOT ENC B+	Differential Encoder Input. For single ended encoder signals, leave the B-terminal open.	I
	7	MOT ENC B-		I
	8	MOT ENC I+	Differential Encoder Input. For single ended encoder signals, leave the I-terminal open.	I
	9	MOT ENC I-		I
	10	-Hall A*	See CN4-1. Leave open in case of single ended Hall sensors.	I
	11	-Hall B*	See CN4-2. Leave open in case of single ended Hall sensors.	I
	12	SGND	Signal ground	SGND
	13	+5V OUT	+5V @ 250mA max. Short-circuit protected.	O
	14	Reserved		
	15	-Hall C*	See CN4-3. Leave open in case of single ended Hall sensors.	I

CN3 – I/O Connector:

CONNECTOR	PIN	NAME	DESCRIPTION	I/O
CN3	1	USER OUTPUT 0	Programmable digital output. Isolated, 24VDC, referenced to USER GND	O
	2	USER OUTPUT 1	Programmable digital output. Isolated, 24VDC, referenced to USER GND	O
	3	USER GND	Ground reference for user outputs and inputs.	GND
	4	NODE ALARM	SynqNet network error. Isolated, 24VDC, referenced to USER GND	O
	5	BRAKE	Brake output, controlled directly via SynqNet. Isolated, 24VDC, referenced to USER GND	O
	6	AGND	Analog ground	AGND
	7	+ DIFF. INPUT 0	Differential input. 5V TTL., non-isolated. Programmable function: capture	I
	8	- DIFF. INPUT 0		I
	9	OUTPUT PULL-UP	5K Pull-up for user outputs.	I
	10	NODE DISABLE	Node disable input. Isolated, 24VDC range. Referenced to sensor common (SENSCOMMON).	I
	11	LIMIT +	Positive limit input. Isolated, 24VDC range. Referenced to sensor common (SENSCOMMON).	I
	12	LIMIT -	Negative limit input. Isolated, 24VDC range. Referenced to sensor common (SENSCOMMON).	I
	13	HOME	Home switch input. Isolated, 24VDC range. Referenced to sensor common (SENSCOMMON).	I
	14	USER INPUT 0	Programmable digital input. Isolated, 24VDC, referenced to USER GND	I
	15	USER INPUT 1	Programmable digital input. Isolated, 24VDC, referenced to USER GND	I
	16	SENSCOMMON	Sensor common. Used with E-stop, limit +, limit -, and home inputs. Can be used as a ground reference or as a pull-up for these inputs.	COMMON
	17	+ DIFF. INPUT 1	Differential input. 5V TTL., non-isolated. Programmable function: capture	I
	18	- DIFF. INPUT 1		I
	19	SGND	Digital ground	SGND
	20	+ DIFF. OUTPUT 0	Differential output. 5V TTL., non-isolated. Programmable function: step&dir, divide-by-N	O
	21	- DIFF. OUTPUT 0		O
	22	+ DIFF. OUTPUT 1	Differential output. 5V TTL., non-isolated. Programmable function: step&dir, divide-by-N	O
	23	- DIFF. OUTPUT 1		O
	24	+ANALOG IN	Programmable, differential analog input, +/- 10V range, 14-bit.	I
	25	-ANALOG IN		I

	26	AGND	Analog ground.	AGND
--	----	------	----------------	------

CN1 – SYNQNET™ INTERFACE:

CONNECTOR	PIN	NAME	DESCRIPTION	I/O
CN1	1	RD+	100BaseT receiver	I
	2	RD-		I
	3	TD+	100BaseT transmitter	O
	6	TD-		O
	4, 5, 7, 8	N/C	Not connected	

CN2 – SYNQNET™ INTERFACE:

CONNECTOR	PIN	NAME	DESCRIPTION	I/O
CN2	1	TD+	100BaseT transmitter	O
	2	TD-		O
	3	RD+	100BaseT receiver	I
	6	RD-		I
	4, 5, 7, 8	N/C	Not connected	

**ORDERING INFORMATION:**

Standard model: DQ111EE40A8BDCX

X indicates the current revision letter.

**MOUNTING DIMENSIONS:**

