

BE15A SERIES BRUSHLESS SERVO AMPLIFIERS

Models: BE12A6, BE15A8, BE15A8-H

FEATURES:

- Surface-mount technology
- Small size, low cost, ease of use
- DIP switch selectable modes:
current, open loop,
encoder velocity BE series,
Hall velocity BE-H series
- Four quadrant regenerative operation
- Agency Approvals:



BLOCK DIAGRAM:

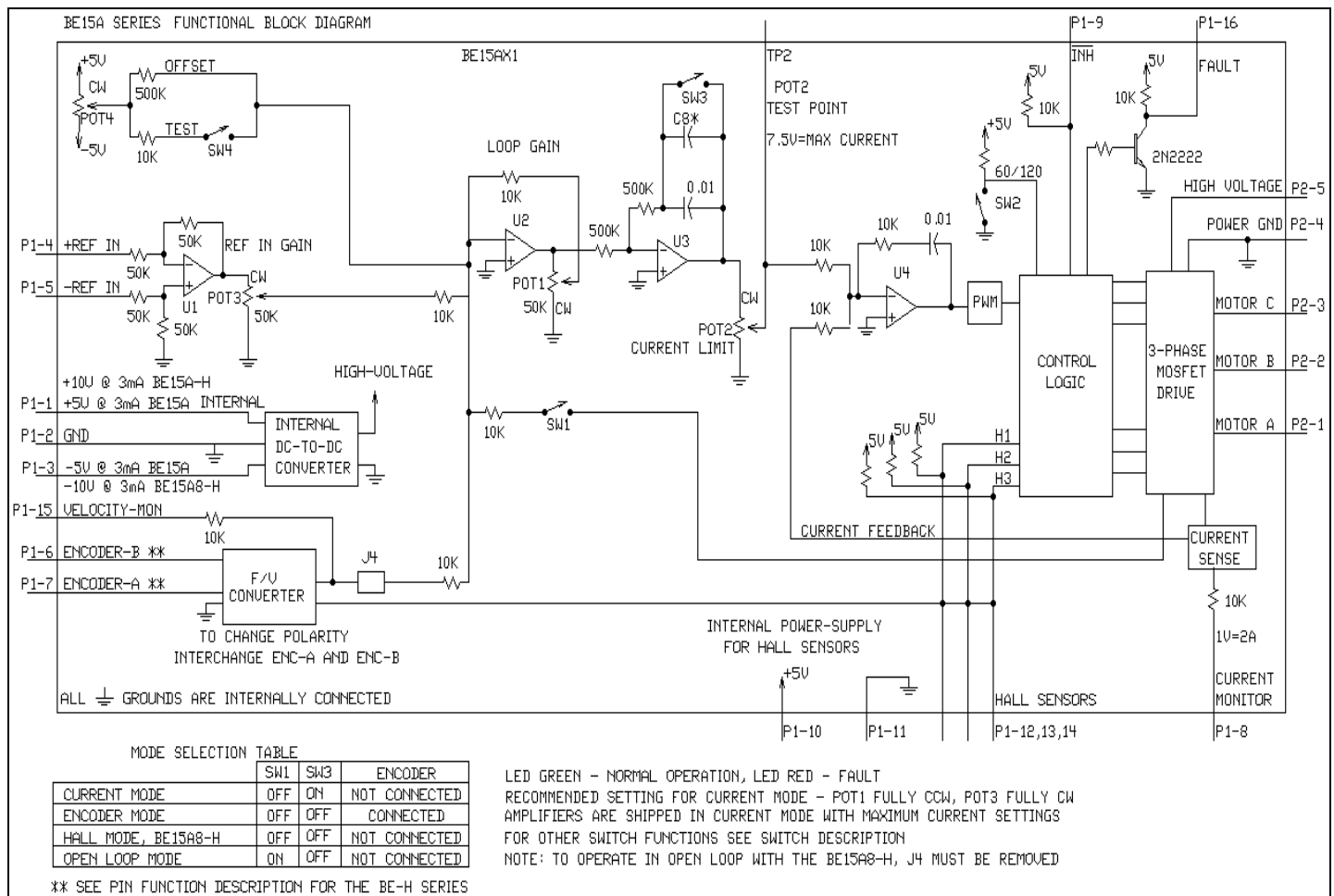

DESCRIPTION: The BE15A Series PWM servo amplifiers are designed to drive brushless DC motors at a high switching frequency. A single red/green LED indicates operating status. BE15A Series amplifiers are fully protected against over-voltage, over-current, over-heating and short-circuits. They interface with digital controllers or can be used as stand-alone drives. These models require only a single unregulated DC power supply. Loop gain, current limit, input gain and offset can be adjusted using 14-turn potentiometers. The offset adjusting potentiometer can also be used as an on-board input signal for testing purposes, when SW4 (DIP switch) is ON.

SPECIFICATIONS:

POWER STAGE SPECIFICATIONS	MODELS		
	BE12A6	BE15A8	BE15A8-H
DC SUPPLY VOLTAGE	20-60 V	20-80 V	20-80 V
PEAK CURRENT (2 sec. maximum)	± 12 A	± 15 A	± 15 A
MAXIMUM CONTINUOUS CURRENT	± 6 A	± 7.5 A	± 7.5 A
MINIMUM LOAD INDUCTANCE*	200 µH	250 µH	250 µH
SWITCHING FREQUENCY	33 kHz ±15%		
HEATSINK (BASE) TEMPERATURE RANGE	0° to + 65°C, disables if > 65°C		
POWER DISSIPATION AT CONTINUOUS CURRENT	18 W	30 W	30 W
OVER-VOLTAGE SHUT-DOWN (self reset)	62 V	86 V	86 V
BANDWIDTH (load dependent)	2.5 kHz	2.5 kHz	2.5 kHz

MECHANICAL SPECIFICATIONS	
POWER CONNECTOR	Screw terminals
SIGNAL CONNECTOR	Molex connector
SIZE	5.09 x 2.98 x 0.99 inches 129.3 x 75.8 x 25.1 mm
WEIGHT	10 oz. 0.28 kg

*Low inductance motors (pancake" and "basket-wound) require external inductors.

PIN FUNCTIONS:

CONNECTOR	PIN	NAME	DESCRIPTION / NOTES	I/O
P1	1	BE Series +5V @ 3mA BE-H Series +10V @ 3 mA	For customer use	O
	2	SIGNAL GND	Reference ground	GND
	3	BE Series -5V @ 3 mA BE-H Series -10V @ 3 mA	For customer use	O
	4	+REF IN	Differential reference input, maximum ± 15 V, 50K input resistance	I
	5	-REF IN		
	6	BE: ENCODER-B IN	Encoder input, 5V CMOS level	I
		BE-H: HALL VEL DIR	Connect to P1-7 or leave open. Changes the polarity of the velocity feedback signal.	
	7	BE: ENCODER-A IN	Encoder input, 5V CMOS level	I
		BE-H: HALL VEL DIR GND	GND reference for Hall Velocity Direction Signal	
	8	CURRENT MONITOR OUT	Current monitor, 1V = 2A	O
	9	_____ INHIBIT IN	This TTL level input signal turns off all power devices of the "H" bridge when pulled to ground. This inhibit will cause a fault condition and a red LED. For inverted inhibit input, see section "G".	I
	10	+V HALL 30 mA OUT	Power for HALL sensors, short circuit protected, +6 V @ +30 mA	O
	11	GND		GND
	12	HALL 1	HALL sensor inputs, logic levels, internal 5 K Ω pull-up. Maximum low level input is 1.5 V, minimum high level input is 3.5 V.	I
	13	HALL 2		
	14	HALL 3		
15	VELOCITY MONITOR OUT	Velocity monitor output BE Series 1V=22 kHz Encoder frequency BE-H Series 1V=120 Hz Hall frequency	O	
16	FAULT OUT (red LED)	TTL level output becomes high during output short circuit, over-voltage, over temperature, inhibit, and during power-up reset. Fault condition indicated by red LED.	O	
P2	1	MOTOR A	Motor phase A connection	O
	2	MOTOR B	Motor phase B connection	O
	3	MOTOR C	Motor phase C connection	O
	4	POWER GND	Power ground	GND
	5	HIGH VOLTAGE	DC power input	I

SWITCH FUNCTIONS:

SWITCH	FUNCTION DESCRIPTION	SETTING	
		ON	OFF
1	Duty-cycle feedback	Open loop	No effect
2	60 / 120 degree commutation phasing setting	120 degree	60 degree
3	Loop integrator. This capacitor normally ensures "error-free" operation in velocity mode by reducing the error-signal (output of summing amplifier) to zero.	Shorts out the velocity loop integrator capacitor	Velocity/voltage loop integrator operating
4	Test / Offset. Sensitivity of the "offset" pot. Used as an on-board reference signal in test mode.	Test	Offset

POTENTIOMETER FUNCTIONS:

POTENTIOMETER	DESCRIPTION	TURNING CW
Pot 1	Loop gain adjustment in open loop & velocity modes. Turn this pot fully ccw in current mode.	Increases loop gain
Pot 2	Current limit. It adjusts both continuous and peak current limit by maintaining their ratio (50%).	Increases current limit
Pot 3	Reference gain. It adjusts the ratio between input signal and output variables (voltage, current, velocity).	Increases reference input gain
Pot 4	Test / Offset. Used to adjust any imbalance in the input signal or in the amplifier. When SW4 (DIP switch) is ON, the sensitivity of this pot is greatly increased thus it can be used as an on-board signal source for testing purposes. See section "G".	N/A

OPERATING MODE SELECTION

These modes can be selected by the DIP switches according to the chart in the functional block diagram:

- Current mode
- Open loop mode
- BE amplifiers, Encoder velocity mode
- BE-H amplifier, Hall velocity mode

APPLICATION NOTE: J4 must be removed for the BE15A8-H to operate in open loop mode.

SET-UP: See section "G" for set-up instructions and additional application notes.

CURRENT LIMIT ADJUSTMENTS:

These amplifiers feature peak and continuous current limit adjustments. Potentiometer 2, the current limiting potentiometer, has 12 active turns plus 1 inactive turn at each end and is approximately linear. Thus, to adjust the current limit turn the potentiometer fully counter-clockwise, then turn clockwise to the appropriate value.

TP2 is the input to the internal current amplifier stage. Since the output current is proportional to TP2, the adjusted current limit can easily be observed at this test point without connecting the motor. Note that a command signal must be applied to the reference inputs to obtain a reading on TP2. The maximum peak current value equals 7.25 V at this point and the maximum continuous current value equals 3.63 V at this point. Example: Using the BE12A6, $7.25V=12A$.

The actual current can be monitored at pin P1-8.

TYPICAL SYSTEM WIRING: See section "G" .

ORDERING INFORMATION:

Models: BE12A6X, BE15A8X, BE15A8X-H

X indicates the current revision letter.

MOUNTING DIMENSIONS: See page F-7.

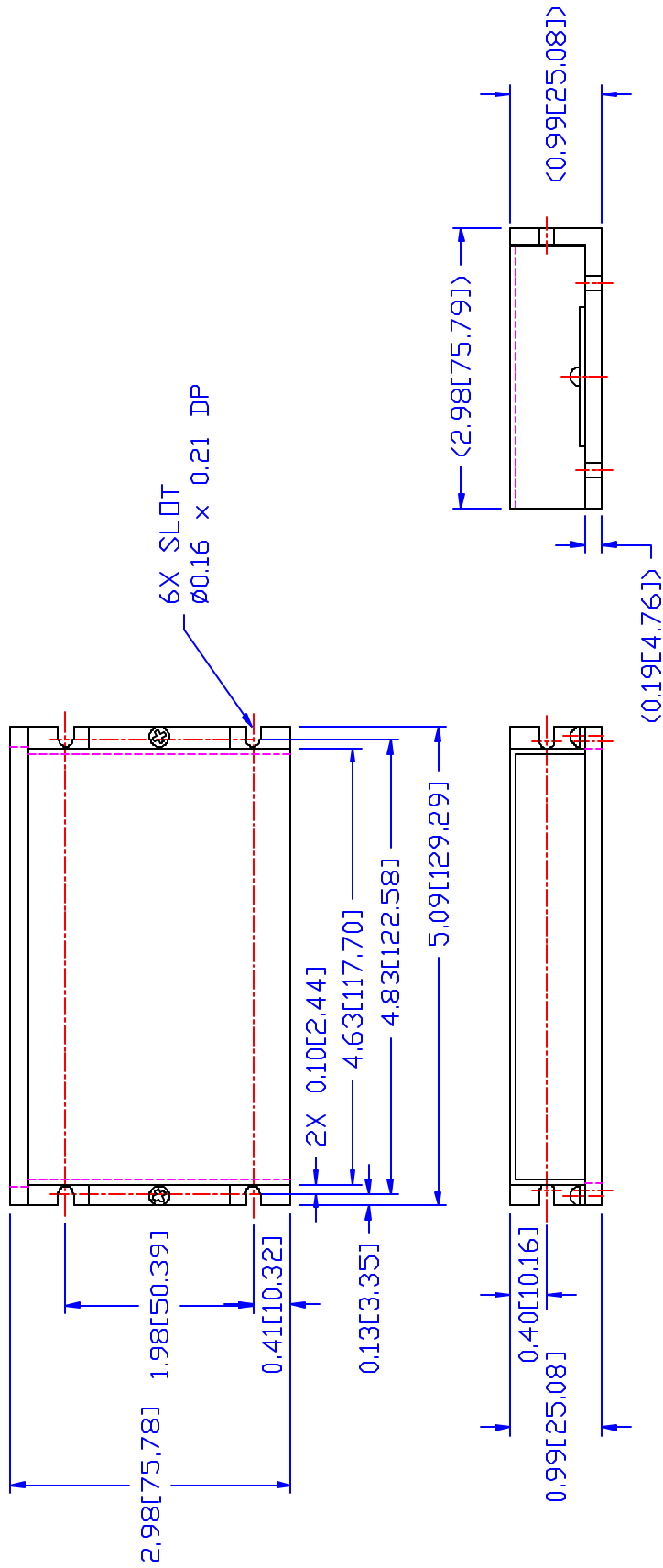

NOTE: DIMENSIONS IN [] ARE IN MM.

B	CHANGE ADDRESS ON TITLE BLOCK	09/18/01	RB
A	UPDATE DWG. FORMAT	08/22/96	RB
REV	DESCRIPTION	DATE	BY
UNLESS OTHERWISE SPECIFIED, DIMENSIONS ARE IN INCHES TOLERANCES .XX ± .010 .XXX ± .005 DO NOT SCALE DRAWING			
ADVANCED MICROPOSITION CONTROLS PWM SERVO AMPLIFIERS 9805 Calle Tecate, Cananillo, CA 92002			
TITLE: MOUNTING DIMENSIONS B12A, 25A, BE12A SERIES			
DRAWN BY: ROBERTO		DATE: 09/27/95	REV: B
CHECK BY:		DATE:	MB12A
DESIGN APPROVED:		DATE:	SCALE: NONE
USED ON:			SHT. 1 OF 1