

Description

The 25A20DD PWM servo amplifier is designed to drive brush type DC motors. The PWM frequency is determined by the PWM input signal. The drive is fully protected against over-voltage, over-current, over-heating and short circuits across motor, ground and power leads. The drive interfaces with digital controllers that have a digital PWM output but can also be used as a stand-alone system when using Pot 2. The 25A20DD drive requires only a single unregulated DC power supply as all logic and control voltages are generated internally. PWM input determines the output duty cycle. "Direction In" determines which side of the "H bridge" output is switching. Current limit can be reduced by Pot 1 (14 turn potentiometer), by the DIP switches and/or by an external current limiting resistor. The voltage at the current monitor pin P1-15 is proportional to the actual motor current.

Power Range

Peak Current	25 A
Continuous Current	12.5 A
Supply Voltage	40 - 190 VDC



Features

- ▲ Four Quadrant Regenerative Operation
- ▲ Optically Isolated Digital Inputs
- ▲ Built-in PWM Generator
- ▲ Adjustable Current Limits
- ▲ High Switching Frequency
- ▲ Digital Fault Output Monitor
- ▲ Drive Status LED
- ▲ Single Supply Operation

MODES OF OPERATION

- Direct PWM

COMMAND SOURCE

- PWM and Direction

COMPLIANCES & AGENCY APPROVALS

- UL
- cUL
- CE Class A (LVD)
- CE Class A (EMC)
- RoHS

BLOCK DIAGRAM

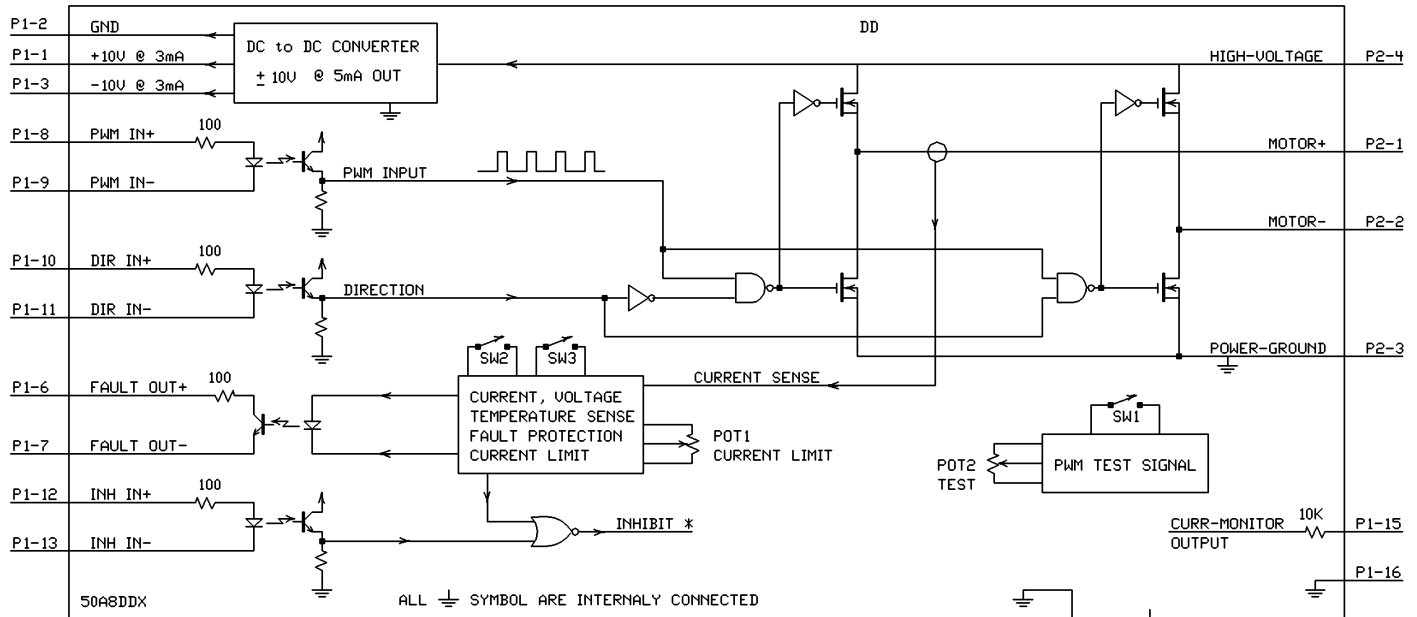

TRUTH TABLE X = NO EFFECT

DIR	INH	PWM	+MOT	-MOT
X	H	X	OFF	OFF
H	L	H	L	H
H	L	L	L	L
L	L	H	H	L
L	L	L	L	L

LED: GREEN - NORMAL OPERATION ; RED - FAULT
 SW1 - DISABLES PWM IN & DIR IN , THE OUTPUT IS CONTROLLED BY POT2
 SW2 - REDUCES THE CURRENT LIMIT TO 60% OF MAX. WHEN OFF
 SW3 - REDUCES THE CURRENT LIMIT TO 80% OF MAX. WHEN OFF
 SW2 & SW3 REDUCE THE CURRENT LIMIT TO 40% OF MAX. WHEN BOTH OFF
 POT1 - REDUCES CURRENT LIMIT FROM 100% TO 10% WHEN TURNED CCW
 * - INHIBIT TURNS OFF ALL MOSFETS (NOT SHOWN ON DIAGRAM FOR CLARITY)

OPTIONAL CURR.LMT RESISTOR

R =	OPEN	5K	2K	1K	0K
Cur.Lmt %	100	80	66	50	10

Information on Approvals and Compliances



US and Canadian safety compliance with UL 508c, the industrial standard for power conversion electronics. UL registered under file number E140173. Note that machine components compliant with UL are considered UL registered as opposed to UL listed as would be the case for commercial products.



Compliant with European CE for both the Class A EMC Directive 2004/108/EC on Electromagnetic Compatibility (specifically EN 61000-6-4:2007 and EN 61000-6-2:2005) and LVD requirements of directive 2006/95/EC (specifically EN 60204-1:2006), a low voltage directive to protect users from electrical shock.



RoHS (Reduction of Hazardous Substances) is intended to prevent hazardous substances such as lead from being manufactured in electrical and electronic equipment.

SPECIFICATIONS

Power Specifications		
Description	Units	Value
DC Supply Voltage Range	VDC	40 - 190
DC Bus Over Voltage Limit	VDC	195
Maximum Peak Output Current ¹	A	25
Maximum Continuous Output Current	A	12.5
Maximum Continuous Output Power	W	2256
Maximum Power Dissipation at Continuous Current	W	119
Minimum Load Inductance (Line-To-Line) ²	µH	250
Low Voltage Supply Outputs	-	±10 VDC (3 mA)
Switching Frequency Range	kHz	5 - 20
Control Specifications		
Description	Units	Value
Command Sources	-	PWM and Direction
Commutation Methods	-	Brush Type
Modes of Operation	-	Direct PWM
Motors Supported	-	Single Phase (Brushed, Voice Coil, Inductive Load)
Hardware Protection	-	Over Current, Over Temperature, Over Voltage, Short Circuit (Phase-Phase & Phase-Ground)
Primary I/O Logic Level	-	5V TTL
Mechanical Specifications		
Description	Units	Value
Agency Approvals	-	CE Class A (EMC), CE Class A (LVD), cUL, RoHS, UL
Size (H x W x D)	mm (in)	186.7 x 111.7 x 25.4 (7.4 x 4.4 x 1)
Weight	g (oz)	680 (24)
Heatsink (Base) Temperature Range ³	°C (°F)	0 - 65 (32 - 149)
Storage Temperature Range	°C (°F)	-40 - 85 (-40 - 185)
Form Factor	-	Panel Mount
P1 Connector	-	16-pin, 2.54 mm spaced, friction lock header
P2 Connector	-	4-contact, 11.10 mm spaced, tri-barrier terminal block

Notes

1. Maximum duration of peak current is ~2 seconds. Peak RMS value must not exceed continuous current rating of the drive.
2. Lower inductance is acceptable for bus voltages well below maximum. Use external inductance to meet requirements.
3. Additional cooling and/or heatsink may be required to achieve rated performance.

PIN FUNCTIONS

P1 - Signal Connector			
Pin	Name	Description / Notes	I/O
1	+10V 3mA OUT	±10 V @ 3 mA low power supply for customer use. Short circuit protected. Reference ground common with signal ground.	O
2	GND		GND
3	-10V 3mA OUT		O
4	CURRENT LIMIT	Used to reduce the factory preset maximum current limit. See details below.	I
5	GND		GND
6	+FAULT	Opto-isolated Fault Output (+5 V). Output transistor turns on during output short circuit, over voltage, over temperature, inhibit, and during power-up reset. Fault condition indicated by red LED.	O
7	-FAULT		O
8	+PWM	Opto-isolated Pulse Width Modulation Input (+5 V). Activating opto-couple activates bridge output.	I
9	-PWM		I
10	+DIR	Opto-isolated Direction Input (+5 V). Activating opto-couple inverts bridge output polarity.	I
11	-DIR		I
12	+INHIBIT	Opto-isolated Inhibit Input (+5 V). Activating opto-couple enables bridge.	I
13	-INHIBIT		I
14	RESERVED	Reserved	-
15	CURRENT MONITOR	Current Monitor. Analog output signal proportional to the actual current output. Scaling is 3.8 A/V. Measure relative to Monitor Ground.	O
16	MONITOR GND		GND

P2 - Power Connector			
Pin	Name	Description / Notes	I/O
1	+MOT	Positive Motor Output	O
2	-MOT	Negative Motor Output	O
3	PWR GND	Power Ground (Common With Signal Ground)	GND
4	HIGH VOLT	DC Power Input	I

Pin Details

CURRENT LIMIT (P1-4)

This pin can be used to reduce the peak and continuous current limit, while maintaining their ratio (50%), by connecting an external current limiting resistor between this pin (P1-4) and signal ground. 100% current limit means no reduction. See table below.

Current Limit Resistor	OPEN	5 kΩ	2 kΩ	1 kΩ	0 Ω (SHORT)
Current Limit %	100	80	66	50	10

HARDWARE SETTINGS

Switch Functions

Switch	Description	Setting	
		On	Off
1	Disables the PWM and direction inputs and enables the internal test signal.	Internal Test Signal	External Signal
2	Adjusts the current limit setting. See details below.	-	-
3	Adjusts the current limit setting. See details below.	-	-

Additional Details

Switches 2 and 3 can be used to reduce the peak and continuous current limit to a percentage given in the table below. 100% means no reduction.

Current Limit %	Switch Settings	
	Switch 2	Switch 3
40	OFF	OFF
60	OFF	ON
80	ON	OFF
100	ON	ON

Potentiometer Functions

Potentiometer	Description	Turning CW
1	Current limit. Adjusts both continuous and peak current limit while maintaining their ratio (50%). Adjustment ranges from 100% to 10% of maximum current limit.	Increases limit
2	PWM test signal adjustment. Used to adjust the duty-cycle/direction of the on-board test signal.	Increases positive direction command

Note: Potentiometers are approximately linear and have 12 active turns with 1 inactive turn on each end.

MECHANICAL INFORMATION

P1 - Signal Connector

Connector Information		16-pin, 2.54 mm spaced, friction lock header
Mating Connector	Details	Molex: P/N 22-01-3167 (connector) and P/N 08-50-0114 (insert terminals)
	Included with Drive	Yes

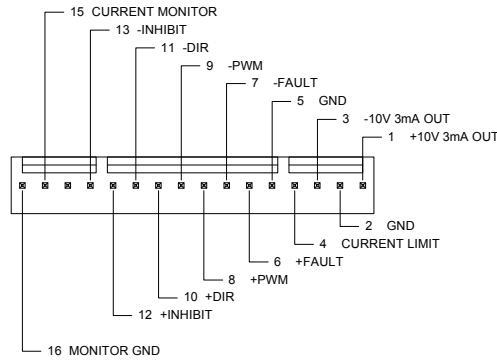

P2 - Power Connector

Connector Information		4-contact, 11.10 mm spaced, tri-barrier terminal block
Mating Connector	Details	Not applicable
	Included with Drive	Not applicable

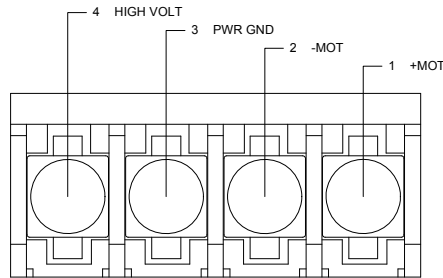

MOUNTING DIMENSIONS

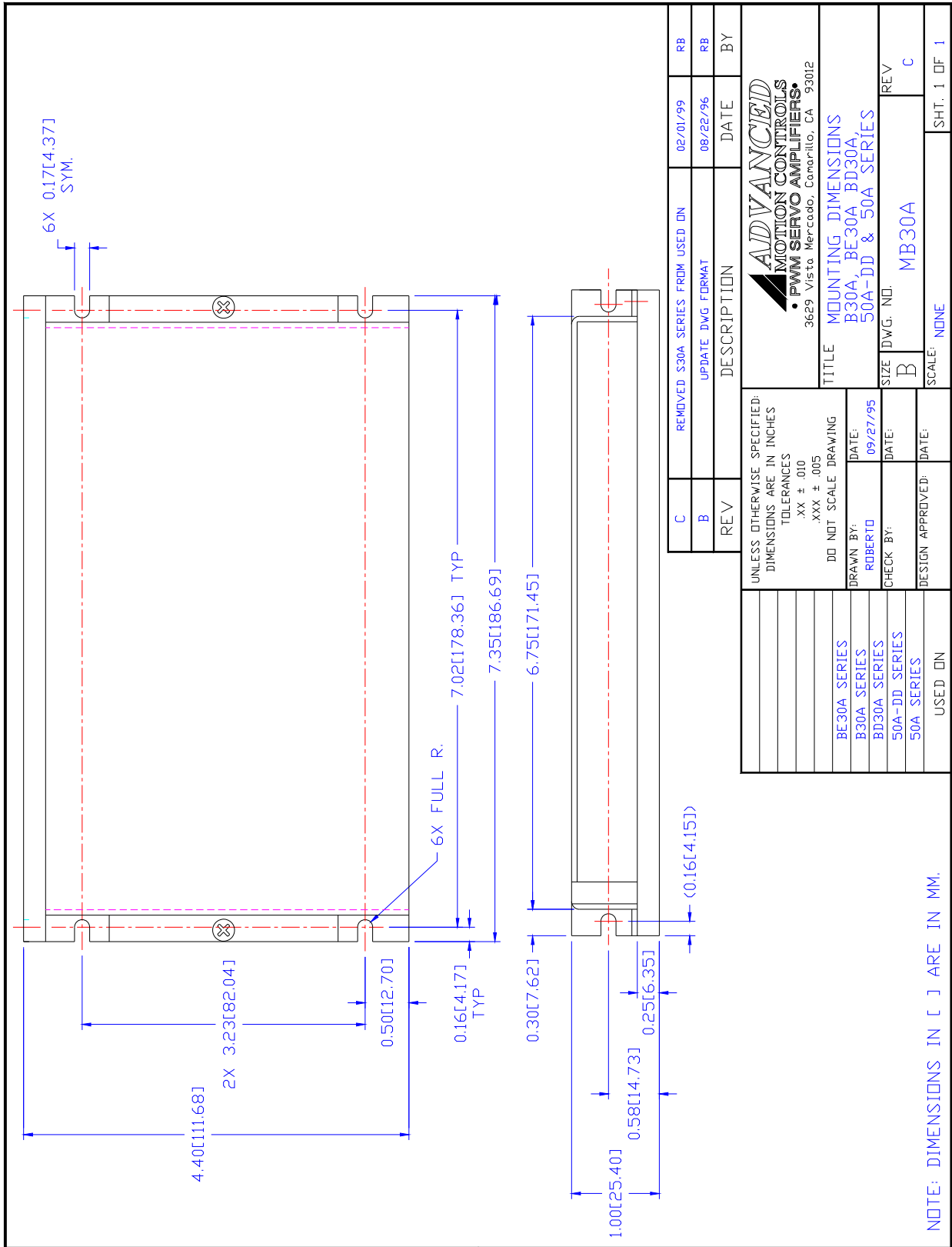

PART NUMBERING INFORMATION

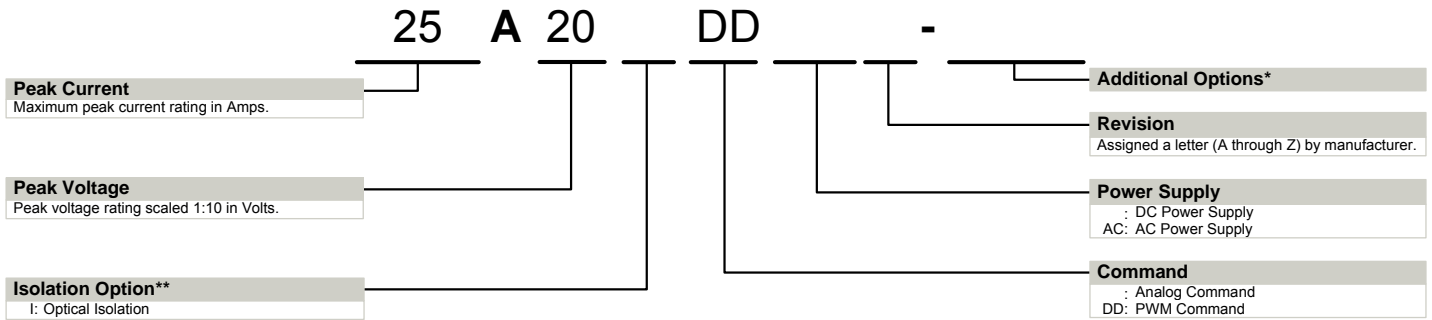

* Options available for orders with sufficient volume. Contact *ADVANCED* Motion Controls for more information.
 ** Isolation comes standard on all AC supply drives and most DC supply drives 200V and above. Consult selection tables of the website or the drive datasheet block diagram to see if isolation is included.

ADVANCED Motion Controls analog series of servo drives are available in many configurations. Note that not all possible part number combinations are offered as standard drives. All models listed in the selection tables of the website are readily available, standard product offerings.

ADVANCED Motion Controls also has the capability to promptly develop and deliver specified products for OEMs with volume requests. Our Applications and Engineering Departments will work closely with your design team through all stages of development in order to provide the best servo drive solution for your system. Equipped with on-site manufacturing for quick-turn customs capabilities, *ADVANCED* Motion Controls utilizes our years of engineering and manufacturing expertise to decrease your costs and time-to-market while increasing system quality and reliability.

Examples of Modifications and Customized Products

- | | |
|---|--|
| <ul style="list-style-type: none"> ▲ Integration of Drive into Motor Housing ▲ Mount OEM PCB onto Drive Without Cables ▲ Multi-axis Configuration for Compact System ▲ Custom PCB and Baseplate for Optimized Footprint ▲ RTV/Epoxy Components for High Vibration ▲ OEM Specified Connectors for Instant Compatibility ▲ OEM Specified Silkscreen for Custom Appearance ▲ Increased Thermal Limits for High Temp. Operation | <ul style="list-style-type: none"> ▲ Integrate OEM Circuitry onto Drive PCB ▲ Custom Control Loop Tuned to Motor Characteristics ▲ Custom I/O Interface for System Compatibility ▲ Preset Switches and Pots to Reduce User Setup ▲ Optimized Switching Frequency ▲ Ramped Velocity Command for Smooth Acceleration ▲ Remove Unused Features to Reduce OEM Cost ▲ Application Specific Current and Voltage Limits |
|---|--|

Feel free to contact Applications Engineering for further information and details.

Available Accessories

ADVANCED Motion Controls offers a variety of accessories designed to facilitate drive integration into a servo system. Visit www.a-m-c.com to see which accessories will assist with your application design and implementation.

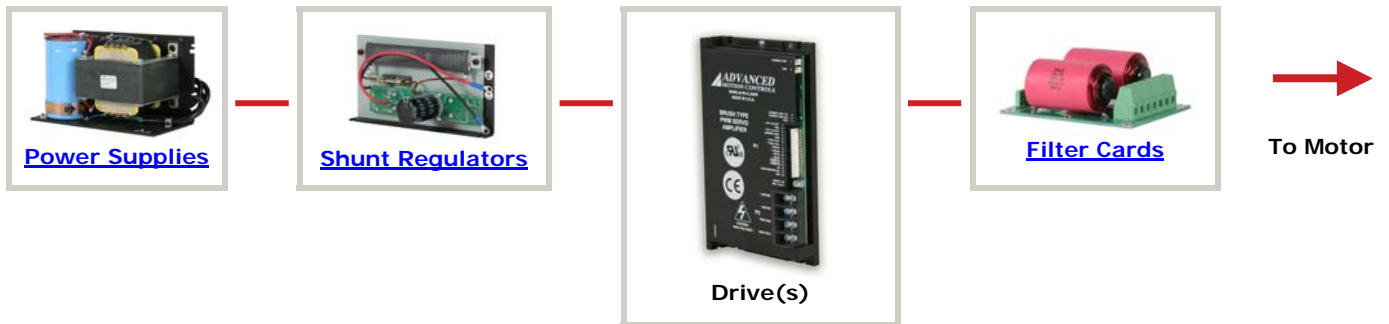

All specifications in this document are subject to change without written notice. Actual product may differ from pictures provided in this document.